

## IM/T

VIDEOCITOTELEFONO  
VIDEO ENTRY TELEPHONE  
VIDEOSPRECHTELEFON  
MONITEUR VIDEO/TELEPHONE  
MONITOR CON TELEFONO  
VIDEOPORTEIRO  
COM TELEFONE

ISTRUZIONI

INSTRUCTIONS

ITALIANO

ENGLISH

## IM/TC

VIDEOCITOTELEFONO  
A COLORI  
COLOUR VIDEO  
ENTRY TELEPHONE  
FARBVIDEOSPRECHTELEFON  
MONITEUR VIDEO/TELEPHONE  
EN COULEURS  
MONITOR COLOR  
CON TELEFONO  
VIDEOPORTEIRO A CORES  
COM TELEFONE

ANLEITUNG

INSTRUCTIONS

INSTRUCCIONES

INSTRUÇÕES

DEUTSCH

FRANÇAIS

ESPAÑOL

PORTUGUÊS









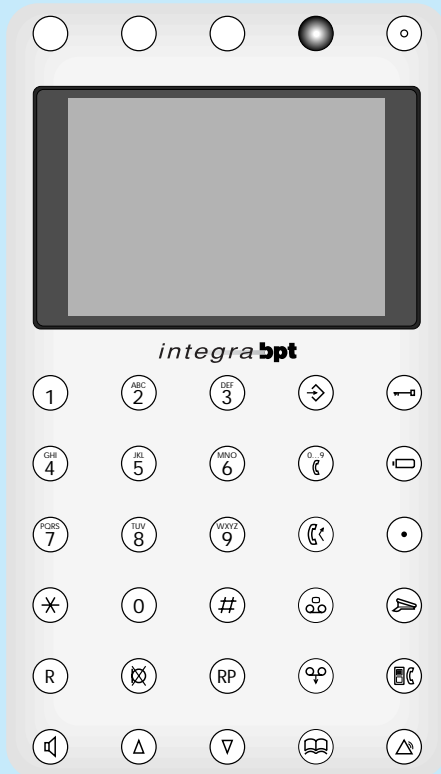
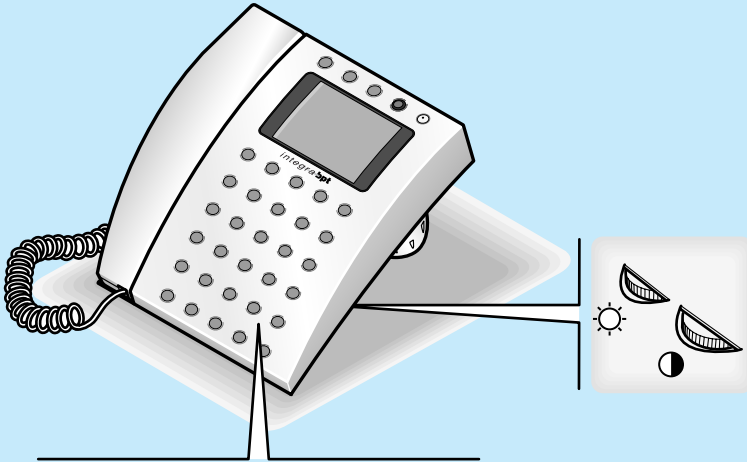

























# INDICE

Simbologia .....	4	<b>Istruzioni per l'utente</b>	
<b>Istruzioni per l'installatore</b>		<b>Utilizzo .....</b>	<b>16</b>
Avvertenze .....	6	- Chiamata .....	16
Generalità .....	7	- Chiamata viva-voce	
Collegamenti .....	8	(con cornetta agganciata) .....	16
Programmazione .....	9	- Tasto RP .....	16
- Configurazione di default .....	9	- Tasto mute .....	16
- Programmazione codice di		- Tasto R (flash) .....	16
chiamata dell'apparecchio		- Tasto di servizio .....	17
collegato all'interfaccia IT/300 .....	9	- Tasto numeri brevi .....	17
- Memorizzazione		- Tasti regolazione del volume	
dei numeri brevi .....	10	in viva-voce .....	17
- Memorizzazione di un numero		- Tasti funzione videocitofono .....	17
per chiamata di servizio .....	10		
- Impostazione della durata			
del flash (tasto R) .....	11		
- Impostazione della durata			
della pausa .....	11		
- Modifica del tipo di selezione .....	12		
- Impostazione del volume			
della suoneria .....	12		
- Impostazione della tonalità			
della suoneria .....	13		
- Selezione del tipo di apparecchiatura			
a cui l'apparecchio viene connesso			
per le funzioni videocitfoniche .....	13		
- Ripristino della configurazione			
di default .....	14		
<b>Caratteristiche tecniche .....</b>	<b>15</b>		

# SIMBOLOGIA



# SIMBOLOGIA

			Tastiera telefonica 12 tasti standard		Tasto autoinserimento/selezione posto esterno
					Tasto ausiliario (*)
					Tasto di chiamata portiere (*)
					Tasto di commutazione videocitofono/telefono (*)
	Tasto R (flash)			Tasto di servizio	
	Tasto mute			Regolazione luminosità	
	Tasto RP (ripetizione ultimo numero)			Regolazione contrasto mod. IM/T e saturazione colore mod. IM/TC (*)	
	Tasto viva-voce		<b>LED</b>	Segnalatore luminoso rosso di modalità viva-voce. Durante la programmazione del telefono il LED è acceso.	
	Tasto incremento volume		<p>(*) Tasti utilizzabili se l'apparecchio è collegato ad impianti videocitofonici.</p>		
	Tasto decremento volume				
	Tasto di programmazione				
	Tasto numeri brevi				
	<p>Tasti utilizzabili per funzioni ausiliarie esterne</p>				
					
					
					
			Tasto apriporta (*)		

---

## AVVERTENZE

Leggere attentamente le avvertenze contenute nel seguente manuale in quanto forniscono importanti indicazioni riguardanti la sicurezza d'uso, d'installazione e manutenzione.

Dopo aver tolto l'imballaggio assicurarsi dell'integrità dell'apparecchio.

Gli elementi dell'imballaggio (sacchetti in plastica, polistirolo espanso, ecc.) non devono essere lasciati alla portata dei bambini in quanto potenziali fonti di pericolo.

Lo smaltimento degli imballi deve essere effettuato nel rispetto delle norme vigenti.

L'esecuzione dell'impianto deve essere rispondente alle norme di sicurezza vigenti.

**Non far passare i cavi telefonici in percorsi comuni a quelli dei cavi elettrici.**

Installare l'apparecchio in ambienti non polverosi, lontano da apparecchiature che possano generare disturbi elettrici di alta frequenza quali saldatrici, motori elettrici, forni a microonde, condizionatori d'aria, ecc.

Questo apparecchio dovrà essere destinato unicamente all'uso per il quale è stato espressamente concepito; qualunque uso diverso è da considerarsi improprio e pericoloso.

Il costruttore non può essere considerato responsabile per eventuali danni derivanti da usi impropri, erronei ed irragionevoli.

Per l'eventuale riparazione rivolgersi solamente ad un centro di assistenza tecnica autorizzato dal costruttore.

Il mancato rispetto di quanto sopra può compromettere la sicurezza dell'apparecchio.

L'installatore deve assicurarsi che le informazioni per l'utente, dove previste, siano presenti sugli apparecchi.

Tutti gli apparecchi costituenti l'impianto devono essere destinati esclusivamente per l'uso per cui sono stati concepiti.

---

# GENERALITA'

Videocitotелефono da tavolo IM/T (IM/TC) completo di cavo telefonico (2 m) per il collegamento alla linea telefonica urbana. Mobile in ABS e schermo fumè.

L'apparecchio permette la connessione, tramite interfaccia IT/300, a reti telefoniche sia di tipo decadico che di tipo multifrequenza. E' munito di funzione viva-voce.

L'apparecchio è dotato di pulsanti dedicati per interagire in modo semplice con il sistema 300 videocitofonico **bpt** attraverso opportuna interfaccia telefonica.

## Funzioni principali

- Volume nota di chiamata regolabile.
- Funzione viva-voce.
- Compatibilità con sistema decadico o multifrequenza.
- Comandi per impianti videocitofonici (per l'attuazione di questi comandi è necessario l'uso dell'interfaccia telefonica **bpt**).
- Durata pausa programmabile.
- Scansione posti esterni e/o telecamere supplementari.
- Autoinserimento.
- Comando apertura porta.
- Chiamata portiere.
- Comandi ausiliari.

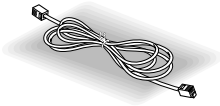

Cavo telefonico

---

# COLLEGAMENTI

## Connettore CN1

Viene utilizzato per il collegamento della cornetta all'apparecchio.

## Connettore CN2

Viene utilizzato per effettuare il collegamento alla linea telefonica urbana.

**NOTA.** L'apparecchio va collegato solo su linee telefoniche analogiche non su linee digitali ISDN.

## Connettore CN3

Viene utilizzato per collegare l'alimentatore supplementare.

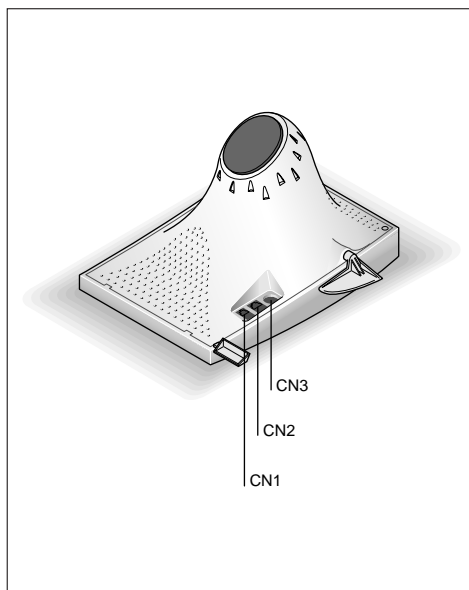



---

# PROGRAMMAZIONE

## Configurazione di default

- Volume di chiamata: 3 (livello massimo).
- Nota di chiamata: melodia 1.
- Volume viva-voce: 3 (livello massimo).
- Tipo di selezione linea: DTMF.
- Durata pausa: 1 s.
- Pulsante R (flash): 100 ms.
- Tasti funzione videocitofono: utilizzabili con l'interfaccia telefonica **bpt**.

Si può entrare in modo programmazione, sia con cornetta sollevata che in modalità viva-voce.

L'entrata in programmazione è segnalata dal LED rosso e dall'assenza del segnale di linea.

Per la programmazione di più funzioni non è necessario uscire e rientrare dalla modalità programmazione.

*Durante la programmazione la pressione dei tasti è accompagnata da un suono breve, la memorizzazione dei dati da un suono più lungo, gli errori da un suono prolungato.*

**AVVERTENZA.** Se la programmazione viene effettuata durante il collegamento con la linea urbana, dopo circa un minuto l'azione di dissuasione della centrale può disturbare il proseguo della programmazione.

In questo caso riagganciare la cornetta e riprendere la programmazione dal punto interrotto.

## Programmazione codice di chiamata dell'apparecchio collegato all'interfaccia IT/300

L'apparecchio, una volta collegato alla propria interfaccia telefonica, deve essere programmato con la procedura riportata nelle istruzioni dell'interfaccia IT/300.

# PROGRAMMAZIONE

## Memorizzazione dei numeri brevi



Sollevare la cornetta

oppure



premere il tasto viva-voce.



Premere il tasto **PROGRAMMAZIONE**.



Premere il tasto **NUMERI BREVI**.

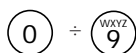

Premere il tasto a cui va associato il numero telefonico (0-9).



Comporre il numero desiderato (max. 20 cifre) (\*).



Premere il tasto **NUMERI BREVI** per memorizzare.



Premere il tasto **PROGRAMMAZIONE**.



Riagganciare la cornetta oppure



premere il tasto viva-voce.

Ripetere l'operazione per memorizzare il numero successivo. Si possono memorizzare fino a 10 numeri.

*(\*) Se il telefono è collegato ad un centralino è necessario inserire una pausa tra lo 0 (numero per il passaggio alla linea urbana) e il numero telefonico.*

*Per inserire una pausa premere il tasto RP: es. 0 RP 0123 456789.*

*La durata della pausa può essere raddoppiata premendo due volte il tasto RP.*

## Memorizzazione di un numero per chiamata di servizio

Questa programmazione può essere utile, ad esempio, per chiamare un numero telefonico di uso frequente, oppure di evitare di comporre numeri ripetitivi, quali prefisso urbano o di altra rete di telefonia fissa.



Sollevare la cornetta

oppure



premere il tasto viva-voce.



Premere il tasto **PROGRAMMAZIONE**.



Premere il tasto di **SERVIZIO**



Comporre il numero desiderato (max. 20 cifre) (\*).



Premere il tasto di **SERVIZIO** per memorizzare.



Premere il tasto **PROGRAMMAZIONE**.



Riagganciare la cornetta oppure



premere il tasto viva-voce.

*(\*) Se il telefono è collegato ad un centralino è necessario inserire una pausa tra lo 0 (numero per il passaggio alla linea urbana) e il numero successivo.*

*Per inserire una pausa premere il tasto RP: es. 0 RP 0123 456789.*

*La durata della pausa può essere raddoppiata premendo due volte il tasto RP.*

# PROGRAMMAZIONE

## Impostazione della durata del flash (tasto R)



Solleverare la cornetta  
oppure



premere il tasto viva-voce.



Premere il tasto **PROGRAMMAZIONE**.



Premere il tasto **R**.

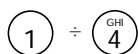

Premere il numero relativo alla durata che si intende impostare (**1÷4**) (vedi capitolo CARATTERISTICHE TECNICHE).



Premere **R** per memorizzare.



Premere il tasto **PROGRAMMAZIONE**.



Riagganciare la cornetta  
oppure



premere il tasto viva-voce.

## Impostazione della durata della pausa



Solleverare la cornetta  
oppure



premere il tasto viva-voce.



Premere il tasto **PROGRAMMAZIONE**.



Premere il tasto **RP**.

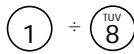

Premere il numero relativo alla durata che si intende impostare (**1÷8**) (vedi capitolo CARATTERISTICHE TECNICHE).



Premere **RP** per memorizzare.



Premere il tasto **PROGRAMMAZIONE**.



Riagganciare la cornetta  
oppure



premere il tasto viva-voce.

# PROGRAMMAZIONE

## Modifica del tipo di selezione



Solleverre la cornetta  
oppure



premere il tasto viva-voce.



Premere il tasto **PROGRAMMAZIONE**.



Premere il tasto \* per la selezione DTMF.



Premere il tasto # per la selezione DECADICA.



Premere il tasto **PROGRAMMAZIONE**.



Riagganciare la cornetta  
oppure



premere il tasto viva-voce.

## Impostazione del volume della suoneria



Solleverre la cornetta  
oppure



premere il tasto viva-voce.



Premere il tasto **PROGRAMMAZIONE**.



Premere il tasto **5**. Viene emessa dall'altoparlante la melodia della suoneria con il livello di volume precedentemente programmato.

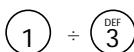

Premere i tasti **1÷3** per fissare il volume desiderato (vedi capitolo CARATTERISTICHE TECNICHE).



Premere nuovamente il tasto **5** per terminare l'impostazione.



Premere il tasto **PROGRAMMAZIONE**.



Riagganciare la cornetta  
oppure



premere il tasto viva-voce.

# PROGRAMMAZIONE

## Impostazione della tonalità della suoneria



Solleverare la cornetta

oppure



premere il tasto viva-voce.



Premere il tasto **PROGRAMMAZIONE**.



Premere il tasto **6**. Viene emessa dall'altoparlante la melodia della suoneria con il livello di volume precedentemente programmato.

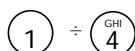

Premere i tasti **1÷4** per fissare la tonalità desiderata (vedi capitolo CARATTERISTICHE TECNICHE).



Premere nuovamente il tasto **6** per terminare l'impostazione.



Premere il tasto **PROGRAMMAZIONE**.



Riagganciare la cornetta

oppure



premere il tasto viva-voce.

## Selezione del tipo di apparecchiatura a cui l'apparecchio viene connesso per le funzioni videocitofoniche



Solleverare la cornetta

oppure



premere il tasto viva-voce.



Premere il tasto **PROGRAMMAZIONE**.



Premere il tasto **7**.



Premere il tasto **1** se l'apparecchio è connesso con l'interfaccia telefonica **bpt**.



Premere il tasto **2** se l'apparecchio è connesso con un centralino telefonico PABX CT1/6 o CT2/8.



Premere il tasto **3** se l'apparecchio è connesso con un centralino telefonico PABX CT1/6U, CT2/8U o CT2/8E.



Premere il tasto **7** per terminare l'impostazione.



Premere il tasto **PROGRAMMAZIONE**.



Riagganciare la cornetta

oppure



premere il tasto viva-voce.

---

# PROGRAMMAZIONE

## Ripristino della configurazione di default



Sollevare la cornetta

oppure



premere il tasto viva-voce.



Premere il tasto **PROGRAMMAZIONE**.



Premere due volte il tasto 0.



Premere il tasto **PROGRAMMAZIONE**.



Riagganciare la cornetta

oppure



premere il tasto viva-voce.

**ATTENZIONE.** Con questa operazione vengono cancellati tutti i numeri memorizzati.

# CARATTERISTICHE TECNICHE

- Funzionamento viva-voce.
- Possibilità di memorizzare un numero per chiamata di servizio (20 cifre max.).
- Possibilità di memorizzare fino a 10 numeri telefonici (20 cifre max. per numero)
- Ripetizione dell'ultimo numero composto.
- Suoneria regolabile in volume a 3 livelli (minimo, medio, massimo).
- Suoneria regolabile in tonalità a 4 melodie.
- Comandi videocitofonici (apriporta, chiamata portiere, commutazione videocitofono/telefono, ausiliario/luce scale).
- Durata flash regolabile: 1 = 100 ms, 2 = 120 ms, 3 = 300 ms, 4 = 600 ms.
- Durata pausa regolabile da 1 a 8 s: 1 = 1 s, ..., 8 = 8 s.
- Alimentazione telefono: dalla linea urbana o dall'interfaccia telefonica.
- Temperatura di funzionamento: da 0 °C a +35 °C.
- Umidità relativa: 90% senza condensa.

## Monitor b/n IM/T

- Standard video: CCIR (EIA).
- Cinescopio: CRT 5" (12,5 cm) a 90°.
- Alimentazione: 12÷24 Vca, 14÷24 Vcc.
- Assorbimento: 8 W.
- Accensione in presenza del segnale video.
- Impedenza d'ingresso video: 100  $\Omega$ .
- Banda passante a -3 dB: 5 MHz.
- Frequenza orizzontale: 15.625 Hz (15.750 Hz EIA).
- Frequenza verticale: 50 Hz (60 Hz EIA).

## Monitor a colori IM/TC

- Standard video: PAL.
- Display: LCD colore 3,5" a matrice attiva di 112.320 punti.
- Alimentazione: 12÷16 Vca, 14÷18 Vcc
- Assorbimento: 6 W max.
- Accensione in presenza del segnale video.
- Impedenza d'ingresso video: 100  $\Omega$ .
- Banda passante a -3 dB: 5 MHz.

L'apparecchio è omologato secondo le norme CTR 37 e CTR 38 e soddisfa la norma EN 60950, relativa alla sicurezza elettrica, e la direttiva 89/336/EEC modificata con 93/68/EEC, relative alla compatibilità elettromagnetica.

Approvazione europea rilasciata dal TÜV Rheinland Product Safety GmbH

# CE 0197 X

# UTILIZZO

## Chiamata



Sollevare la cornetta.



Comporre il numero desiderato.



Al termine della conversazione, riagganciare la cornetta.

## Chiamata viva-voce (con cornetta agganciata)



Premere il tasto viva voce. Si accende il LED rosso.



Comporre il numero desiderato.



Al termine della conversazione, ripremere il tasto viva-voce.

## Tasto RP



Sollevare la cornetta



oppure  
premere il tasto viva-voce.



Premere il tasto **RP** per effettuare la ripetizione dell'ultimo numero composto.

## Tasto MUTE



Premere il tasto **MUTE** se durante una conversazione telefonica si desidera impedire temporaneamente l'ascolto da parte dell'interlocutore (microfono, microtelefono ed altoparlante vengono disattivati).



Premere nuovamente il tasto **MUTE** per riabilitare la conversazione.

## Tasto R (flash)



Questo tasto può venire usato quando il videocitofono è collegato ad un centralino telefonico. Consultare il libretto di istruzioni del centralino usato per conoscere l'utilizzo del tasto **R**.



# UTILIZZO

## Tasto di SERVIZIO

Chiamata ad un numero telefonico di uso frequente



Premere il tasto di **SERVIZIO**. Il telefono si pone in modalità viva-voce e viene inviato il numero memorizzato.

## Tasti regolazione del volume in viva-voce



Usando il tasto **REGOLAZIONE VOLUME** durante la conversazione in viva-voce, il volume dell'altoparlante può essere incrementato o decrementato.

## Chiamata tramite prefisso



Premere il tasto di **SERVIZIO**. Il telefono si pone in modalità viva-voce e viene inviato il prefisso memorizzato.



Comporre il numero desiderato.



Sollevare la cornetta se si vuole escludere la funzione viva-voce.

## Tasti funzione videocitofono



Ausiliario/Luce scale



Apriporta



Inserimento posto esterno



Chiamata portiere



Commutazione videocitofono/telefono

## Tasto NUMERI BREVI



Premere il tasto **NUMERI BREVI**.

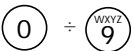

Premere il tasto (0÷9) a cui è stato associato il numero telefonico desiderato.

I tasti **APRIPORTA** e **AUSILIARIO/LUCE SCALE** sono abilitati solo a seguito di una chiamata o autoinserimento.

*NOTA. Le funzioni videocitofoniche sono consentite solo con la cornetta sollevata o in modalità viva-voce.*



---

# CONTENTS







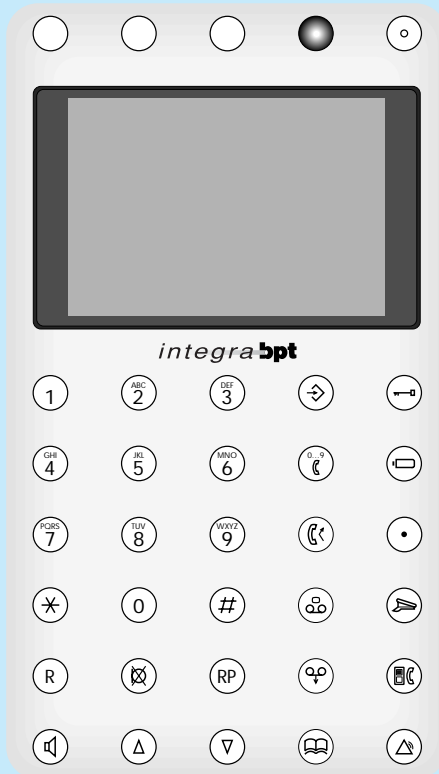
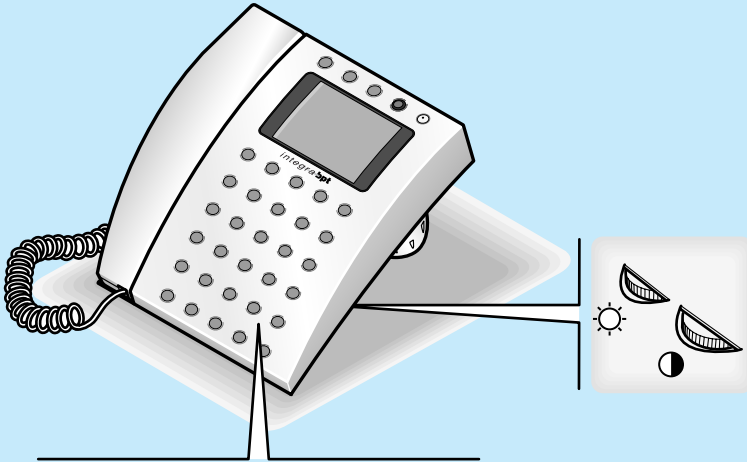

























Symbols .....	20	<b>Instructions for the user</b>	
<b>Instructions for the installer</b>		<b>Operation .....</b>	<b>32</b>
Warnings .....	22	- Making call .....	32
Foreword .....	23	- Hands-free call	
Connections .....	24	(with receiver hung up) .....	32
Programming .....	25	- RP key .....	32
- Default settings .....	25	- Mute key .....	32
- Programming the call code		- R key (flash) .....	32
of the unit connected to		- Service key .....	33
the IT/300 interface .....	25	- One-touch dialling .....	33
- Storing one-touch numbers .....	26	- Hands-free volume control .....	33
- Storing service call number .....	26	- Video entry function keys .....	33
- Flash length setup (R key) .....	27		
- Pause length setup .....	27		
- Changing dialling mode .....	28		
- Bell volume setup .....	28		
- Bell tone setup .....	29		
- Selecting the type of unit			
the telephone is to be connected			
to for the video entry functions .....	29		
- Resetting default settings .....	30		
<b>Technical features .....</b>	<b>31</b>		

# SYMBOLS

ENGLISH



# SYMBOLS

			Telephone push-but- tons 12 standard keys		Auxiliary key (!)
					Porter call key (!)
					Entry video handset/telephone transfer key (!)
					Service key
	R key (flash)				Brightness control
	Mute key				Contrast control mod. IM/T and colour saturation mod. IM/TC (!)
	RP key (repeats last number)			<b>LED</b>	Red hands-free mode LED. During the programming of the telephone, the LED is lit.
	Hands-free key			<b>(!) Keys which can be used if the unit is con- nected to video entry control systems.</b>	
	Increase volume key				
	Decrease volume key				
	Programming key				
	One-touch dialling key				
	Keys used for independent auxiliary functions				
					
					
					
					
	Door lock release key (!)				
	Entry panel self-connection/ selection key				

---

# WARNINGS

Read the warnings contained herein carefully as they provide important instructions for safe operation, installation and maintenance.

Having removed the packaging, make sure the unit is intact.

The packaging materials (plastic bags, foam polystyrene, etc.) must be kept out of the reach of children as they represent potential sources of danger.

The material must be disposed of according to the laws in force.

The installation of the system must comply with the safety rules in force.

**Do not run telephone cables in the same raceways as electrical cables.**

Install the unit in a fairly dust-free room, away from units liable to generate high-frequency electrical noise such as welding machines, electric motors, microwave ovens, air conditioners, etc.

This unit must be used only for the use for which it was explicitly designed; any other use shall be considered improper and hazardous.

The manufacturer cannot be held responsible for any damage as a result of improper, incorrect and unreasonable use.

When in need of repair work, contact only technical servicing centres authorized by the manufacturer.

Failure to comply with the above provisions may compromise the safety of the unit.

The installer must make sure that the user information, where applicable, is to be found on the unit.

All the equipment making up the system must be used only for the user for which they were designed.

---

# FOREWORD

Table-top video entry telephone IM/T (IM/TC) complete with telephone cable (2 m) for connection to the local telephone line. ABS housing and smoked screen.

The unit enables connections to both decadic and multifrequency telephone networks by means of the IT/300 interface.

It features a hands-free function.

The unit comes complete with dedicated push-button used to interact in a simple manner with the **bpt** video entry control system 300 via a special **bpt** telephone interface.

## Main functions

- Telephone bell volume control.
- Hands-free function.
- Compatibility with decadic or multifrequency systems.
- Video entry system controls (controls only enabled when using the **bpt** telephone interface).
- Programmable pause length.
- Scanning of entry panels and/or additional surveillance cameras.
- Self-connection to entry panel.
- Door-lock release control.
- Porter call.
- Auxiliary controls.

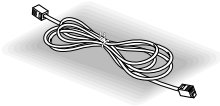

Telephone cable

---

# CONNECTIONS

## Connector CN1

This is used for connecting the unit's receiver.

## Connector CN2

This is used for connecting the unit to the local telephone line.

**NOTE.** The unit must be connected on analogue telephone lines only and not digital ISDN lines.

## Connector CN3

This is used for connecting the additional power supplier.

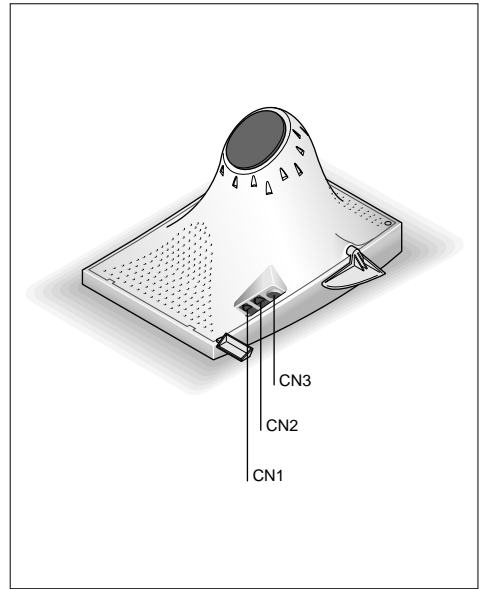



---

# PROGRAMMING

## Default settings

- Call volume: 3 (highest level).
- Call note: melody 1.
- Hands-free volume: 3 (highest level).
- Dialling mode: DTMF.
- Pause length: 1 s.
- R key (flash): 100 ms.
- Video function keys: enabled with **bpt** telephone interface.

The programming mode can be entered either with the receiver lifted or in hands-free mode.

You can tell you have entered programming mode as the red LED comes on and there is no dial tone.

It is not necessary to exit and reenter the programming mode when programming a number of functions.

*During programming, pressing any of the keys produces a short beep, the storing of the data produces a longer sound, and errors an extended beep.*

**WARNING.** If the programming is carried out with the unit connected to the local line, after approx. one minute, the dissuasive action of the telephone exchange may interfere with programming. In this case, hang up the receiver and resume programming from where you left off.

## Programming the call code of the unit connected to the IT/300 interface

Once connected to the relevant telephone interface, the unit must be programmed following the procedure described in the IT/300 interface instructions.

# PROGRAMMING

## Storing one-touch numbers



Lift the receiver

or



press the hands-free key.



Press the **PROGRAMMING** key.



Press the **ONE-TOUCH DIAL** key.

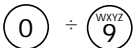

Press the key the telephone number is to be associated with (in the range 0 to 9).



Key in the desired number (max. 20 digits) (\*).



Press the **ONE-TOUCH DIAL** key to save.



Press the **PROGRAMMING** key.



Replace the receiver

or



press the hands-free key.

Repeat the operation to store the next number. Up to 10 different numbers can be stored.

*(\*) If the video entry handset is connected to a switchboard, a pause must be inserted between the 0 (number dialled to get an outside line) and the **telephone number**.*

*To insert a pause, press the **RP** key e.g. 0 **RP** 0123 456789.*

*The length of the pause can be doubled by pressing the **RP** key twice.*

## Storing service call number

This programming option may prove useful for calling a telephone number used frequently, for example, or to avoid dialling repetitive numbers, such as the area code or the code of another fixed telephone network.



Lift the receiver

or



press the hands-free key.



Press the **PROGRAMMING** key.



Press the **SERVICE** key.



Key in the desired number (max. 20 digits) (\*).



Press the **SERVICE** key.



Press the **ONE-TOUCH DIAL** key to save.



Press the **PROGRAMMING** key.



Replace the receiver

or



press the hands-free key.

*(\*) If the video entry handset is connected to a switchboard, a pause must be inserted between the 0 (number dialled to get an outside line) and the **telephone number**.*

*To insert a pause, press the **RP** key e.g. 0 **RP** 0123 456789.*

*The length of the pause can be doubled by pressing the **RP** key twice.*

# PROGRAMMING

## Flash length setup (R key)



Lift the receiver  
or



press the hands-free key.



Press the **PROGRAMMING** key.



Press the **R** key.

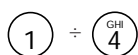

Press the number relating to the length to be set (in the range **1** to **4**) (see section entitled TECHNICAL FEATURES).



Press **R** to save.



Press the **PROGRAMMING** key.



Replace the receiver  
or



press the hands-free key.

## Pause length setup



Lift the receiver  
or



press the hands-free key.



Press the **PROGRAMMING** key.



Press the **RP** key.

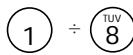

press the number relating to the length to be set (in the range **1** to **8**) (see section entitled TECHNICAL FEATURES).



Press **RP** to save.



Press the **PROGRAMMING** key.



Replace the receiver  
or



press the hands-free key.

# PROGRAMMING

## Changing dialling mode



Lift the receiver

or



press the hands-free key.



Press the **PROGRAMMING** key.



Press the **\*** key for DTMF mode.



Press the **#** key for DECA-DIC mode.



Press the **PROGRAMMING** key.



Replace the receiver

or



press the hands-free key.

## Bell volume setup



Lift the receiver

or



press the hands-free key.



Press the **PROGRAMMING** key.



Press key **5**. The ring melody can be heard through the loudspeaker with the previously set volume level.

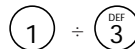

Press key in the range **1** to **3** to select the desired volume (see section entitled TECHNICAL FEATURES).



Press key **5** again to complete the setup.



Press the **PROGRAMMING** key.



Replace the receiver

or



press the hands-free key.

# PROGRAMMING

## Bell tone setup



Lift the receiver

or



press the hands-free key.



Press the **PROGRAMMING** key.



Press key **6**. The ring melody can be heard through the loudspeaker with the previously set volume level.

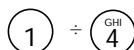

Press key in the range **1 to 4** to select the desired tone (see section entitled TECHNICAL FEATURES).



Press key **6** again to complete the setup.



Press the **PROGRAMMING** key.



Replace the receiver

or



press the hands-free key.

## Selecting the type of unit the telephone is to be connected to for the VIDEO entry functions



Lift the receiver

or



press the hands-free key.



Press the **PROGRAMMING** key.



Press key **7**.



Press key **1** if the telephone is connected with the **bpt** telephone interface.



Press key **2** if the telephone is connected with a CT1/6 or CT2/8 PABX telephone switchboard.



Press key **3** if the telephone is connected with a CT1/6U, CT2/8U or CT2/8E PABX telephone switchboard.



Press key **7** to complete the setup.



Press the **PROGRAMMING** key.



Replace the receiver

or



press the hands-free key.

---

# PROGRAMMING

## Resetting default settings



Lift the receiver

or



press the hands-free key.



Press the **PROGRAMMING** key.



Press key **0** twice.



Press the **PROGRAMMING** key.



Replace the receiver

or



press the hands-free key.

**WARNING.** By this operation all stored telephone numbers will be cancelled.

---

# TECHNICAL FEATURES

- Hands-free function.
- Possibility of storing a service call number (max. 20 digits).
- Possibility of storing up to 10 telephone numbers (max. 20 digits per number).
- Repeat function redials the last number.
- Bell volume control: 3 levels (low, medium, high).
- Adjustable bell tone: 4 melodies.
- Video entry controls (door lock release, porter call, video entry/telephone transfer, auxiliary function/stair light).
- Adjustable flash length: 1 = 100 ms, 2 = 120 ms, 3 = 300 ms, 4 = 600 ms.
- Adjustable pause length in the range 1 to 8 s: 1 = 1 s, ..., 8 = 8 s.
- Telephone power supply: from the local line or telephone interface.
- Working temperature range: from 0 °C to +35 °C.
- Relative humidity: 90% with no condensation.

## Black and white monitor (mod. IM/T)

- Video standard: CCIR (EIA).
- CRT tube: 5" (12.5 cm) 90°.
- Supply voltage: 12÷24 V AC, 14÷24 V DC.
- Current demand: 8 W.
- Switches on when there is a video signal.
- Video input impedance: 100 Ω.
- Bandwidth response at -3 dB: 5 MHz.
- Horizontal frequency: 15,625 Hz (15,750 Hz EIA).
- Vertical frequency: 50 Hz (60 Hz EIA).

## Colour monitor (mod. IMTC/200)

- Video standard: PAL.
- Display: 3,5" colour active matrix LCD with 112,320 dots.
- Supply voltage: 12÷16 V AC, 14÷18 V DC.
- Current demand: max.1 6 W.
- Switches on when there is a video signal.
- Bandwidth response at -3 dB: 5 MHz.

The unit is type approved according to standard CTR 37 and CTR 38 and meets the requirements of the EN 60950 standard relating to electrical safety, and of the 89/336/EEC directive amended with 93/68/EEC directive relating to electromagnetic compatibility.

European approval issued by  
TÜV Rheinland Product Safety GmbH

# CE 0197 X

# OPERATION

## Making call



Lift the receiver.



Dial the desired number.



When the conversation is over, replace the receiver.

## Hands-free call (with receiver hung up)



Press the hands-free key.  
The red LED lights.



Dial the desired number.



When the conversation is over, press the hands-free key again.

## RP key



Lift the receiver



or  
press the hands-free key.



Press the **RP** key to repeat the last number dialled.

## MUTE key



Press the **MUTE** key when, during a telephone call, you want to talk, temporarily, without the person on the other end of the line listening in (microphone, receiver and loudspeaker are disabled).



Press the **MUTE** key again to resume the conversation.

## R key (flash)



This key can be used when the telephone is connected to a telephone switchboard. Consult the user manual of the switchboard used for instructions regarding the use of the **R** key.



# OPERATION

## SERVICE key

### Used to call a frequently dialled number



Press the **SERVICE** key. The telephone automatically switches to hands-free mode and the stored number is dialled.

### Used to dial an area code



Press the **SERVICE** key. The telephone automatically switches to hands-free mode and the stored area code is dialled.



Dial the desired number.



Lift the receiver if you want to disable the hands-free function.

## ONE-TOUCH dialling



Press the **ONE-TOUCH DIAL** key.

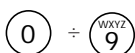

Press the key (in the range **0** to **9**) associated with the telephone number desired.

## Hands-free volume control



The **VOLUME CONTROL** can be used during hands-free conversation to increase or decrease the volume of the loudspeaker.

## VIDEO ENTRY function keys



Auxiliary/Stair light



Door lock release



Inserimento posto esterno



Porter call



Entry video handset/telephone transfer.

The **DOOR LOCK RELEASE** and **AUXILIARY/STAIR LIGHT** keys are only enabled following a call or self-connection.

***NOTE.** The video entry functions can only be used with the receiver lifted or in hands-free mode.*









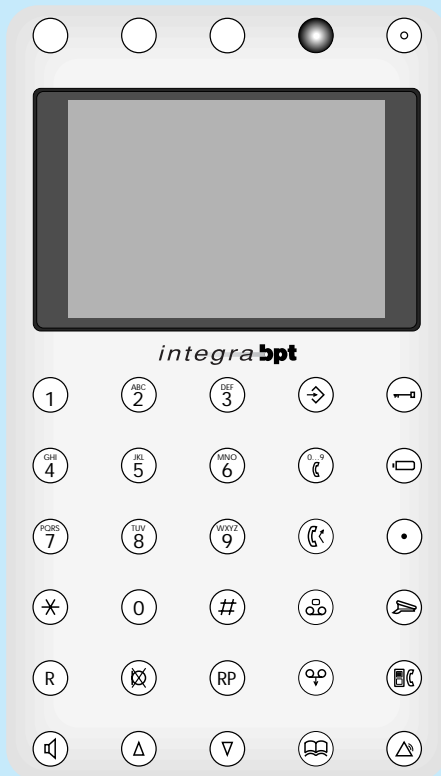
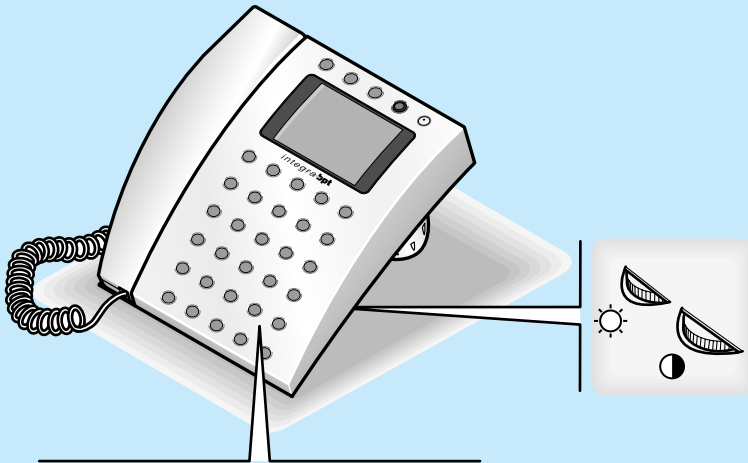

























# INHALTSVERZEICHNIS

Zeichenerklärung	36	<b>Bedienungsanleitung</b>	
<b>Installationsanleitung</b>		<b>Benutzung</b>	48
Anmerkungen	38	- Anruf	48
Allgemeines	39	- Anruf mit Freisprechfunktion (mit angeschlossenem Hörer)	48
Anschlüsse	40	- RP-Taste	48
Programmierung	41	- Mute-Taste	48
- Standardkonfiguration	41	- R-Taste (Flash)	48
- Programmierung des Rufcodes des an die Schnittstelle IT/300 angeschlossenen Geräts	41	- Dienst-Taste	49
- Speichern von Kurwahlnummern	42	- Taste Kurzwahlruffnummern	49
- Speichern einer Amtskennziffer	42	- Taste Lautstärkeregelung der Freisprechfunktion	49
- Eingabe der Flashdauer (R-Taste)	43	- Sprech-/Videofunktionstasten	49
- Eingabe der Pausendauer	43		
- Änderung des Anwählens	44		
- Regelung der Klingellautstärke	44		
- Regelung des Klingeltons	45		
- Auswahl des Gerätetyps, an dem das Telefon für die Videofunktionen anzuschließen ist	45		
- Wiederherstellung der Standardkonfiguration	46		
Technische Daten	47		

# ZEICHENERKLÄRUNG



# ZEICHENERKLÄRUNG

- |  |   |  |                                       |   |   |
|--|---|--|---------------------------------------|---|---|
|    |  |   | Telefontastatur mit 12 Standardtasten |  | Taste zur Selbsteinschaltung/ Auswahl der Außenstation  |
|    |  |   |                                       |  | Zusatzaste (!)  |
|    |  |   |                                       |  | Pförtneruftaste (!)   |
|    |  |   |                                       |  | Umschalttaste Sprechgarnitur/ Telefon (!)   |
|    | R-Taste (Flash)   |    | Mutetaste                             |  | Diensttaste   |
|    | RP-Taste (Wahlwiederholung)   |   |                                       |   | Regelung der Helligkeit   |
|    | Freisprechfunktiontaste   |   |                                       |   | Kontrastregelung Mod. IM/T und Farbsättigung Mod. IM/TC (!)                                     |
|    | Lautstärkezunahmetaste  | <b>LED</b>   |                                       |   | Rote Leuchtanzeige des Freisprechmodus. Während der Programmierung des Telefons ist die LED an. |
|    | Lautstärkeabnahmetaste  |   | Programmiertaste                      |   |   |
|  | Kurzwahlruffnummerntaste  |  |                                       |   |   |
|  | Die Selbsteinschaltung ist auch bei eingehängtem Hörer möglich                    |  |                                       |   |   |
|  |   |  |                                       |   |   |
|  |   |  |                                       |   |   |
|  |   | Türöffnertaste (!)   |                                       |   |   |

(!) Benutzbare Tasten, falls das Gerät an Videosprechanlagen angeschlossen ist.

---

# ANMERKUNGEN

Die Anmerkungen der nachfolgenden Anleitung aufmerksam durchlesen, da sie wichtige Sicherheitshinweise über die Benutzung, Installation und Wartung liefern.

Verpackung abnehmen und sicherstellen, daß das Gerät einwandfrei ist.

Die Verpackungsteile (Plastikbeutel, Schaum- polystyrol, etc.) müssen außerhalb der Reichweite von Kindern aufbewahrt werden, da diese eine Gefahrenquelle darstellen können.

Die Verpackungsteile nicht in die Umwelt freisetzen, sondern sich an die geltenden Gesetze halten.

Der Anlagenbau muß den geltenden Sicherheitsvorschriften entsprechen.

**Telefonkabel nicht zusammen mit elektrischen Kabeln legen.**

Gerät nicht an einem staubigen Ort und fern von Geräten, die elektrische Hochfrequenz- störungen verursachen können, wie Schweißapparate, elektrische Motoren, Mikrowellenherd, Klimaanlage, etc. aufstellen.

Dieses Gerät ausschließlich für die eigens hierfür gedachte Benutzung gebrauchen; eine Zweckentfremdung ist unangebracht und somit gefährlich.

Der Hersteller übernimmt keine Haftung für eventuelle Schäden, die auf eine Zweckentfremdung, eine falsche oder unvernünftige Bedienung zurückzuführen sind.

Im Falle einer Reparatur sich ausschließlich an eine vom Hersteller dazu ermächtigte Kundendienststelle wenden.

Die mangelnde Beachtung des oben Genannten kann die Sicherheit des Geräts beeinträchtigen.

Der Installateur muß sich vergewissern, daß die für den Benutzer erforderlichen Informationen auf der dafür vorgesehenen Stelle auf den Geräten vorhanden sind.

Alle Anlagengeräte dürfen ausschließlich für die hierfür gedachte Benutzung verwendet werden.

---

# ALLGEMEINES

Videotürsprechtelefon als Tischausführung IM/T (IM/TC), ausgestattet mit Telefonkabel (2 m) für den Anschluß an das Ortsnetz.

ABS-Gehäuse und getönte Acrylglas-scheibe. Das Gerät erlaubt den Betrieb an IWW- und MFV-Netzen.

Es ist mit einer Freisprechfunktion ausgerüstet und besitzt Tasten zur einfachen Umschaltung zwischen der **bpt** Videosprechanlage System 300 und der Telefonschnittstelle.

## Funktionen

- Lautstärkeregelung des Ruftons.
- Freisprechfunktion.
- Kompatibilität mit IWW- oder MFV-Systemen.
- Schaltfunktionen für Videosprechanlagen (für die Einschaltung dieser Funktionen ist die Benutzung der **bpt** Telefonschnittstelle erforderlich).
- Programmierbare Pausendauer.
- Abtastung der Außenstationen und/oder Zusatzkameras.
- Selbsteinschaltung.
- Steuerung des Türöffners.
- Pförtneranruf.
- Zusatzsteuerungen.



Telefonkabel

# ANSCHLÜSSE

## Buchse CN1

Wird für den Anschluß des Hörers an das Gerät benutzt.

## Buchse CN2

Wird für den Anschluß an das Ortsnetz benutzt.

**HINWEIS.** Das Gerät darf nur an analogen und nicht an digitalen ISDN-Telefonleitungen angeschlossen werden.

## Buchse CN3

Wird für den Anschluß des Zusatznetzgeräts benutzt.

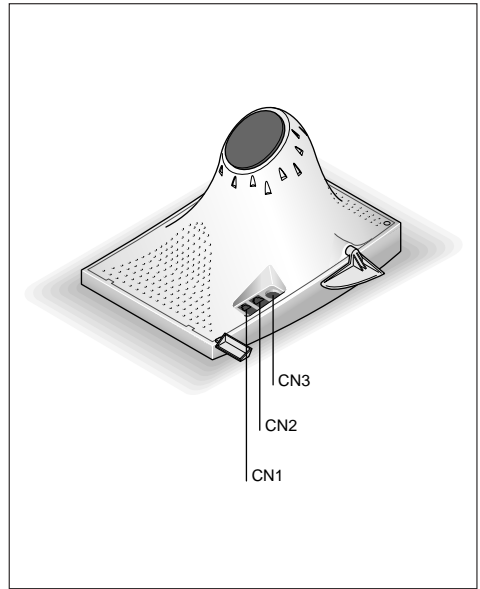



---

# PROGRAMMIERUNG

## Standardkonfiguration

- Ruftonlautstärke: 3 (max. Pegel).
- Rufton: Melodie 1.
- Lautstärke der Freisprechfunktion: 3 (max. Pegel).
- Wählart der Leitung: MFV.
- Pausendauer: 1s.
- R-Taste (Flash): 100 ms.
- Videofunktionstasten: mit **bpt** Telefonschnittstelle benutzbar.

Der Programmiermodus ist sowohl bei abgehobenem Hörer als auch mit der Freisprechfunktion möglich.

Der Programmierbeginn wird durch die Einschaltung der roten Led und das Fehlen des Freizeichens angezeigt.

Falls mehrere Funktionen zu programmieren sind, ist die Beendigung und der Rückruf des Vorgangs Programmiermodus nicht erforderlich.

*Bei der Programmierung wird der Tastendruck von einem Kurztone, die Datenspeicherung von einem längeren Tone, eventuelle Fehler von einem anhaltenden Tone quittiert.*

ANMERKUNG. Falls die Programmierung während der Verbindung mit der Ortsleitung erfolgt, könnte nach circa einer Minute das Fortsetzen der Programmierung durch das Abschreckungsverfahren der Zentrale gestört werden.

In diesem Fall Hörer wieder auflegen und Programmierung an der unterbrochenen Stelle wieder aufnehmen.

## Programmierung des Rufcodes des an die Schnittstelle IT/300 angeschlossenen Geräts

Nachdem das Gerät an die eigene Telefonschnittstelle angeschlossen wurde, muß es nach dem Vorgang, der in der Anleitung über die Schnittstelle IT/300 beschrieben wurde, programmiert werden.

# PROGRAMMIERUNG

## Speichern von Kurzwahlnummern



Hörer abnehmen

oder



Taste Freisprechfunktion drücken.



Taste **PROGRAMMIERUNG** drücken.



Taste **KURZWAHLNUMMERN** drücken.

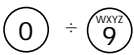

Die Taste, der die Telefonnummer zugeordnet ist, drücken (0≠9).



Die gewünschte Rufnummer wählen (max. 20 Ziffern) (!).



Zur Speicherung Taste **KURZWAHLNUMMERN** drücken.



Taste **PROGRAMMIERUNG** drücken.



Hörer wieder auflegen

oder



Taste Freisprechfunktion drücken.

Um die darauffolgende Rufnummer zu speichern, Vorgang wiederholen. Es können bis zu 10 Rufnummern gespeichert werden.

(!) Falls das Telefon an eine Telefonzentrale angeschlossen ist, ist zwischen der 0 (als möglicher Amtskennziffer) und der Telefonnummer eine Pause einzugeben.

Zur Pauseneingabe **RP**-Taste drücken, z. Bsp. : 0 RP 0123 456789.

Durch zweimaligen **RP**-Tastendruck kann die Pausendauer verdoppelt werden.

## Speichern einer Amtskennziffer

Diese Programmierung kann nützlich sein, um zum Beispiel eine häufig gewählte Telefonnummer zu wählen oder um sich ständig wiederholende Nummern wie die Ortskennzahl oder die Vorwahl eines anderen festen Telefonnetzes zu vermeiden.



Hörer abnehmen

oder



Taste Freisprechfunktion drücken.



Taste **PROGRAMMIERUNG** drücken.



**DIENST**-Taste drücken.



Die gewünschte Rufnummer wählen (max. 20 Ziffern) (!).



Zur Speicherung **DIENST**-Taste drücken.



Taste **PROGRAMMIERUNG** drücken.



Hörer wieder auflegen

oder



Taste Freisprechfunktion drücken.

(!) Falls das Telefon an eine Telefonzentrale angeschlossen ist, ist zwischen der 0 (als möglicher Amtskennziffer) und der Telefonnummer eine Pause einzugeben.

Zur Pauseneingabe **RP**-Taste drücken, z. Bsp. : 0 RP 0123 456789.

Durch zweimaligen **RP**-Tastendruck kann die Pausendauer verdoppelt werden.

# PROGRAMMIERUNG

## Eingabe der Flashdauer (R-Taste)



Hörer abnehmen

oder



Taste Freisprechfunktion drücken.



Taste **PROGRAMMIERUNG** drücken.



R-Taste drücken.

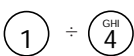

Die jeweilige Nummer der einzugebenden Dauer (1÷4) drücken (siehe Kapitel TECHNISCHE DATEN).



Zur Speicherung R-Taste drücken.



Taste **PROGRAMMIERUNG** drücken.



Hörer wieder auflegen

oder



Taste Freisprechfunktion drücken.

## Eingabe der Pausendauer



Hörer abnehmen

oder



Taste Freisprechfunktion drücken.



Taste **PROGRAMMIERUNG** drücken.



RP-Taste drücken.

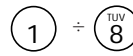

Die jeweilige Nummer der einzugebenden Dauer (1÷8) drücken (siehe Kapitel TECHNISCHE DATEN).



Zur Speicherung RP-Taste drücken.



Taste **PROGRAMMIERUNG** drücken.



Hörer wieder auflegen

oder



Taste Freisprechfunktion drücken.

# PROGRAMMIERUNG

## Änderung des Anwählens



Hörer abnehmen  
oder



Taste Freisprechfunktion drücken.



Taste **PROGRAMMIERUNG** drücken.



Für die MFV-Wählart Taste \* drücken.



Für die IWW-Wählart Taste # drücken.



Taste **PROGRAMMIERUNG** drücken.



Hörer wieder auflegen  
oder



Taste Freisprechfunktion drücken.

## Regelung der Klingellautstärke



Hörer abnehmen  
oder



Taste Freisprechfunktion drücken.



Taste **PROGRAMMIERUNG** drücken.



Taste **5** drücken. Der Lautstärker sendet die Klingelmelodie mit der zuvor eingestellten Lautstärke.

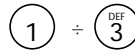

Tasten **1÷3** drücken, um die gewünschte Lautstärke (siehe Kapitel TECHNISCHE DATEN) zu bestimmen.



Erneut Taste **5** drücken, um die Einstellung zu beenden.



Taste **PROGRAMMIERUNG** drücken.



Hörer wieder auflegen  
oder



Taste Freisprechfunktion drücken.

# PROGRAMMIERUNG

## Regelung des Klingeltons



Hörer abnehmen  
oder



Taste Freisprechfunktion drücken.



Taste **PROGRAMMIERUNG** drücken.



Taste **6** drücken. Der Lautstärker sendet die Klingelmelodie mit der zuvor eingestellten Lautstärke.

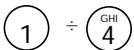

Tasten **1-4** drücken, um den gewünschten Klingelton (siehe Kapitel TECHNISCHE DATEN) zu bestimmen.



Erneut Taste **6** drücken, um die Einstellung zu beenden.



Taste **PROGRAMMIERUNG** drücken.



Hörer wieder auflegen  
oder



Taste Freisprechfunktion drücken.

## Auswahl des Gerätetyps, an dem das Telefon für die VIDEOfunktionen anzuschließen ist



Hörer abnehmen  
oder



Taste Freisprechfunktion drücken.



Taste **PROGRAMMIERUNG** drücken.



Taste **7** drücken.



Taste **1** drücken, wenn das Telefon an die **bpt**-Telefonschnittstelle angeschlossen ist.



Taste **2** drücken, wenn das Telefon an eine Telefonzentrale PABX CT1/6 oder CT2/8 angeschlossen ist.



Taste **3** drücken, wenn das Telefon an eine Telefonzentrale PABX CT1/6U, CT2/8U oder CT2/8E PABX angeschlossen ist.



Erneut Taste **7** drücken, um die Einstellung zu beenden.



Taste **PROGRAMMIERUNG** drücken.



Hörer wieder auflegen  
oder



Taste Freisprechfunktion drücken.

---

## Wiederherstellung der Standardkonfiguration



Hörer abnehmen  
oder



Taste Freisprechfunktion  
drücken.



Taste **PROGRAMMIERUNG** drücken.

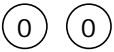

Zweimal Taste 0 drücken.



Taste **PROGRAMMIERUNG** drücken.



Hörer wieder auflegen  
oder



Taste Freisprechfunktion  
drücken.

**ACHTUNG.** Durch diese Maßnahme werden alle gespeicherten Telefonnummern gelöscht.

# TECHNISCHE DATEN

- Freisprechfunktion.
- Speichern einer Amtskennziffer (max. 20 Ziffern).
- Speichern von bis zu 10 Telefonnummern (max. 20 Ziffern pro Nummer).
- Wahlwiederholung der zuletzt gewählten Rufnummer.
- Regelbare 3-Stufen-Klingellautstärke (schwach-mittel-laut).
- Regelbarer Klingelton mit 4 Melodien.
- Steuerelemente der Videosprechanlage (Türöffner, Pförtneranruf, Umschaltung Sprechgarnitur/Telefon, Zusatzfunktion/Treppenlicht).
- Regelbare Flashdauer: 1 = 100 ms, 2 = 120 ms, 3 = 300 ms, 4 = 600 ms.
- Pausendauer regelbar zwischen 1 bis 8 s: 1 = 1 s, ..., 8 = 8 s.
- Telefonstromversorgung: erfolgt durch die Amtsleitung oder Telefonschnittstelle.
- Betriebstemperatur: von 0°C bis +35°C.
- Relative Luftfeuchtigkeit: 90% ohne Kondenswasser.

- Einschaltung bei Videosignal.
- Video-Eingangsimpedanz: 100  $\Omega$ .
- Durchlaßbereich: 5 MHz bei -3 dB.

Das Gerät wurde gemäß den Vorschriften CTR 37 und CTR 38 zugelassen und erfüllt die Vorschrift EN 60950 über die elektrische Sicherheit und die europäische Richtlinie 89/336/EEC, durch 93/68/EEC abgeändert, über die elektromagnetische Kompatibilität.

Die europäische Genehmigung wurde von TÜV Rheinland Product Safety GmbH erlassen

**CE 0197 X**

## Weiß/Schwarz Monitor IM/T

- Stromversorgung: 12÷24 V AC, 14÷24 V DC.
- Stromaufnahme: 8 W.
- Bildröhre: CRT 5-Zoll (12,5 cm) - 90° Ablenkung.
- CCIR Standard (EIA Standard).
- Einschaltung bei Videosignal.
- Video-Eingangsimpedanz: 100  $\Omega$ .
- Durchlaßbereich: 5 MHz bei -3 dB.
- Horizontalfrequenz: 15.625 Hz (15.750 Hz EIA).
- Vertikalfrequenz: 50 Hz (60 Hz EIA).

## Farbmonitor IM/TC

- PAL Standard.
- Bildschirm: 3,5" LCD farbig mit activer Matrix zu 112.320 Bildpunkte.
- Stromversorgung: 12÷16 V AC, 14÷18 V DC.
- Stromaufnahme: max. 6 W.

# BENUTZUNG

## Anruf



Hörer abnehmen.



Die gewünschte Rufnummer wählen.



Nach Gesprächsende, Hörer wieder auflegen.

## Anruf mit Freisprechfunktion (mit angeschlossenem Hörer)



Taste Freisprechfunktion drücken.  
Die rote LED leuchtet auf.



Die gewünschte Rufnummer wählen.



Nach Gesprächsende, Freisprechfunktionstaste drücken.

## RP-Taste



Hörer abnehmen  
oder



Taste Freisprechfunktion drücken.



**RP**-Taste drücken, um die zuletzt gewählte Rufnummer wiederholen.

## MUTE-Taste



**MUTE**-Taste drücken, wenn während eines Telefongesprächs das Zuhören des Gesprächsteilnehmers verhindert werden soll (Mikrofon, Hörer und Lautsprecher werden ausgeschaltet).



Erneut **MUTE**-Taste drücken, um das Gespräch wieder aufzunehmen.

## R-Taste (Flash)



Diese Taste kann nur dann verwendet werden, wenn das Videosprechtelefon an eine Telefonzentrale angeschlossen ist. Zur Verwendung der **R**-Taste ist die Betriebsanleitung der verwendeten Zentrale durchzulesen.



# BENUTZUNG

## DIENST-Taste

Anwählen einer häufig verwendeten Rufnummer



**DIENST**-Taste drücken. Das Telefon schaltet die Freisprechfunktion ein und sendet die gespeicherte Vorwahl.

## Anruf mit Vorwahl



**DIENST**-Taste drücken. Das Telefon schaltet die Freisprechfunktion ein und sendet die gespeicherte Vorwahl.



Die gewünschte Rufnummer wählen.



Hörer abheben, wenn die Freisprechfunktion ausgeschaltet werden soll.

## Taste KURZWahlRUFNUMMERN



Taste **KURZWahlRUFNUMMERN** drücken.

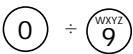

Die Taste (0÷9), der die gewünschte Telefonnummer zugeordnet ist, drücken.

## Taste Lautstärkeregelung der Freisprechfunktion



Durch das Drücken der Taste **LAUTSTÄRKEREGLUNG** während des Gesprächs mit eingeschalteter Freisprechfunktion, kann die Lautstärke des Lautsprechers erhöht oder reduziert werden.

## SPRECH-/VIDEOfunktionstasten



Zusatzfunktion/Treppenlicht



Türöffner



Einschaltung der Außenstation



Pförtneranruf



Umschaltung Videosprechgarnitur/Telefon

Die Tasten **TÜRÖFFNER** und **ZUSATZFUNKTION/TREPPENLICHT** sind nur infolge eines Anrufs oder ihrer Selbsteinschaltung einschaltbar.

***ANMERKUNG.** Die Videofunktionen sind nur bei abgehobenem Hörer oder bei eingeschalteter Freisprechfunktion möglich.*









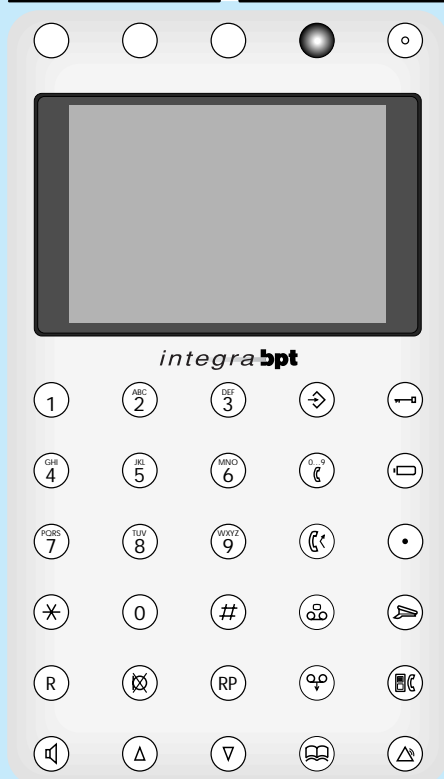
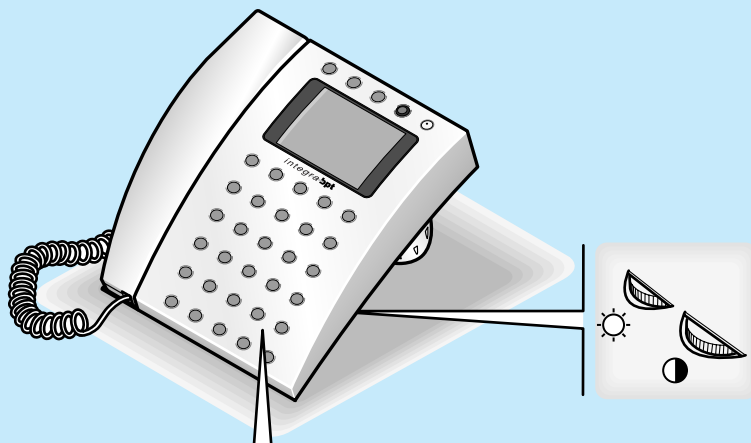

























# SOMMAIRE

Symboles .....	52	<b>Instructions pour l'utilisateur</b>	
<b>Instructions pour l'installateur</b>		<b>Utilisation .....</b>	<b>64</b>
Conseils .....	54	- Appel .....	64
Généralités .....	55	- Appel à vive-voix	
Connexions .....	56	(avec récepteur accroché) .....	64
Programmation .....	57	- Touche RP .....	64
- Configuration par défaut .....	57	- Touche mute .....	64
- Programmation code		- Touche R (flash) .....	64
d'appel de l'appareil		- Touche de service .....	65
relié à l'interface IT/300 .....	57	- Touche numéros courts .....	65
- Mémorisation de numéros courts .....	58	- Touche de réglage du volume	
- Mémorisation d'un numéro		appel à vive-voix .....	65
pour appel de service .....	58	- Touches fonction portier/vidéo .....	65
- Programmation de la			
durée du flash (touche R) .....	59		
- Programmation de la durée			
de la pause .....	59		
- Modification du type de sélection .....	60		
- Programmation du volume			
de la sonnerie .....	60		
- Programmation de la tonalité			
de la sonnerie .....	61		
- Sélection du type d'appareil			
auquel le téléphone est raccordé			
pour les fonctions portier vidéo .....	61		
- Rétablissement de la			
configuration par défaut .....	62		
Caractéristiques techniques .....	63		

# SYMBLES



# SYMBOLES

			Clavier téléphone 12 touches standard		Touche mise en marche automatique/sélection poste extérieur
					
					Touche auxiliaire (*)
					Touche appel concierge (*)
	Touche R (flash)				Touche de commutation moniteur vidéo/téléphone (*)
	Touche mute				Touche de service
	Touche RP (répétition dernier numéro)				Reglage luminosité
	Touche vive-voix				Reglage contraste mod. IM/T et saturation couleur mod. IM/TC (*)
	Touche augmentation volume			<b>LED</b>	Voyant lumineux rouge du mode vive-voix. Pendant la programmation du téléphone, la LED est allumée.
	Touche diminution volume				
	Touche de programmation				
	Touche numéros courts				
	Touches utilisables pour des fonctions auxiliaires extérieures				
					
					
					
			Touche ouvre-porte (*)		

(\*) Touches utilisables si l'appareil est raccordé à des installations de portier vidéo.

---

## CONSEILS

**Lire attentivement les instructions contenues dans le présent livret car elles fournissent d'importantes indications concernant la sécurité d'emploi, d'installation et d'entretien.**

Après avoir sorti l'appareil de son emballage, contrôler s'il est en bon état.

Les éléments de l'emballage (sachets en plastique, polystyrène expansé, etc.) ne doivent pas être laissés à la portée des enfants car ils pourraient être dangereux.

L'élimination de l'emballage doit être fait conformément aux normes en vigueur.

L'exécution de l'installation doit répondre aux normes de sécurité en vigueur.

**Ne pas faire passer au même endroit les câbles du téléphone et les câbles électriques.**

Installer l'appareil dans un local non poussiéreux, loin de tous appareils pouvant créer des dérangements électriques de haute fréquence comme par ex.: soudeuses, moteurs électriques, fours à micro-ondes, climatiseurs, etc.

Cet appareil ne devra être destiné qu'à l'emploi pour lequel il a été expressément conçu. Toute autre utilisation sera considérée comme impropre et dangereuse.

Le constructeur ne sera pas tenu responsable de tous dommages dérivant d'une utilisation inappropriée, erronée et irraisonnée. Pour toute réparation, s'adresser uniquement à un centre de service après-vente agréé.

Le non-respect des indications ci-dessus peut compromettre la sécurité de l'appareil.

L'installateur doit s'assurer que les informations pour l'utilisateur, quand elles sont prévues, soient présentes sur l'appareil.

Tous les appareils constituant l'installation devront être destinés exclusivement à l'emploi pour lequel ils ont été conçus.

---

# GENERALITES

Moniteur avec téléphone IMT (IMTC), en version de table, fourni avec câble téléphonique (2 m) pour le branchement à la ligne téléphonique urbaine. Coque en ABS et écran fumé.

L'appareil peut être raccordé, moyennant l'interface IT/300, à des réseaux téléphoniques à décades ou bien à multifréquence. Il est muni de la fonction vive-voix.

L'appareil est doté de boutons dédiés pour interagir de manière simple avec le système portier vidéo 300 **bpt** au moyen d'une interface téléphonique.

## Fonctions

- Volume note d'appel téléphonique réglable.
- Fonction vive-voix.
- Compatibilité avec système à décades ou multifréquence.
- Commandes pour installations de portier vidéo (pour pouvoir utiliser ces commandes, il est nécessaire d'utiliser l'interface téléphonique **bpt**).
- Durée de la pause programmable.
- Balayage postes extérieurs et/ou télécameras supplémentaires.
- Mise en marche automatique.
- Commande ouvre-porte.
- Appel concierge.
- Commandes auxiliaires.



Câble  
téléphonique

---

# CONNEXIONS

## Connecteur CN1

Il est utilisé pour effectuer la connexion entre le récepteur et l'appareil.

## Connecteur CN2

Il est utilisé pour effectuer la connexion à la ligne téléphonique urbaine.

**NOTE.** L'appareil ne doit être raccordé que sur des lignes téléphoniques analogiques et non pas sur des lignes digitales ISDN.

## Connecteur CN3

Il est utilisé pour effectuer la connexion de l'alimentation supplémentaire.

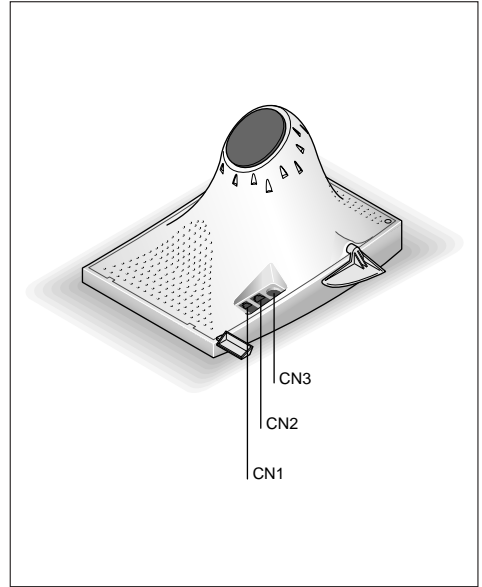



---

# PROGRAMMATION

## Configuration par défaut

- Volume de l'appel: 3 (niveau maximum).
- Note d'appel: mélodie 1.
- Volume vive-voix: 3 (niveau maximum).
- Type de sélection ligne: DTMF.
- Durée pause: 1s.
- Touche R (flash): 100 ms.
- Touches fonction portier vidéo: utilisables avec l'interface téléphonique **bpt**.

On peut accéder au mode programmation aussi bien avec le récepteur soulevé qu'en fonction vive-voix.

L'entrée en mode programmation est signalée par le led rouge et par l'absence de signal de ligne.

Pour la programmation de plusieurs fonctions, il n'est pas nécessaire de sortir et de revenir au mode programmation.

*Pendant la programmation, la pression des touches est accompagnée d'un son court, la mémorisation des données d'un son plus long, les erreurs d'un son prolongé.*

ATTENTION. Si la programmation est effectuée pendant la connexion à la ligne urbaine, après une minute environ, l'action de dissuasion de la centrale peut déranger la continuation de la programmation.

Dans ce cas, raccrocher le récepteur et recommencer la programmation là où vous l'aviez interrompue.

## Programmation code d'appel de l'appareil relié à l'interface IT/300

Une fois raccordé à l'interface téléphonique, l'appareil doit être programmé en suivant les procédures indiquées dans la notice d'emploi de l'interface IT/300.

# PROGRAMMATION

## Mémorisation de numéros courts



Soulever le récepteur  
ou bien



appuyer sur la touche vive-voix.



Appuyer sur la touche **PROGRAMMATION**.



Appuyer sur la touche **NUMEROS COURTS**.

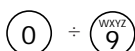

Appuyer sur la touche à laquelle vous associez le numéro de téléphone (0÷9).



Composer le numéro désiré (20 chiffres maxi) (\*).



Appuyer sur la touche **NUMEROS COURTS** pour le mémoriser.



Appuyer sur la touche **PROGRAMMATION**.



Raccrocher  
ou bien



appuyer sur la touche vive-voix.

Répéter cette opération pour mémoriser un autre numéro. Il est possible de mémoriser jusqu'à 10 numéros.

*(\*) Si le téléphone est relié à une centrale de conciergerie, il est nécessaire d'introduire une pause entre le 0 (numéro pour le passage à la ligne urbaine) et le numéro de téléphone.*

*Pour introduire une pause, appuyer sur la touche RP: Ex. 0 RP 0123 456789.*

*La durée de la pause peut être doublée en appuyant deux fois sur la touche RP.*

## Mémorisation d'un numéro pour appel de service

Cette programmation peut être utile par exemple pour appeler un numéro de téléphone que vous composez fréquemment ou bien pour éviter de composer des numéros répétitifs comme l'indicatif d'une ville ou celui d'un autre réseau de téléphonie fixe.



Soulever le récepteur  
ou bien



appuyer sur la touche vive-voix.



Appuyer sur la touche **PROGRAMMATION**.



Appuyer sur la touche de **SERVICE**.



Composer le numéro désiré (20 chiffres maxi) (\*).



Appuyer sur la touche de **SERVICE** pour mémoriser.



Appuyer sur la touche **PROGRAMMATION**.



Raccrocher  
ou bien



appuyer sur la touche vive-voix.

*(\*) Si le téléphone est relié à une centrale de conciergerie, il est nécessaire d'introduire une pause entre le 0 (numéro pour le passage à la ligne urbaine) et le numéro de téléphone.*

*Pour introduire une pause, appuyer sur la touche RP: Ex. 0 RP 0123 456789.*

*La durée de la pause peut être doublée en appuyant deux fois sur la touche RP.*

# PROGRAMMATION

## Programmation de la durée du flash (touche R)



Soulever le récepteur  
ou bien



appuyer sur la touche vive-voix.



Appuyer sur la touche **PRO-GRAMMATION**.



Appuyer sur la touche **R**.

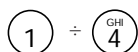

Appuyer sur la chiffre correspondant à la durée que vous souhaitez programmer (**1÷4**) (voir chapitre CARACTERISTIQUES TECHNIQUES).



Appuyer sur **R** pour mémoriser.



Appuyer sur la touche **PRO-GRAMMATION**.



Raccrocher  
ou bien



appuyer sur la touche vive-voix.

## Programmation de la durée de la pause



Soulever le récepteur  
ou bien



appuyer sur la touche vive-voix.



Appuyer sur la touche **PRO-GRAMMATION**.



Appuyer sur la touche **RP**.

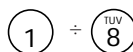

Appuyer sur la chiffre correspondant à la durée que vous souhaitez programmer (**1÷8**) (voir chapitre CARACTERISTIQUES TECHNIQUES).



Appuyer sur **RP** pour mémoriser.



Appuyer sur la touche **PRO-GRAMMATION**.



Raccrocher  
ou bien



appuyer sur la touche vive-voix.

# PROGRAMMATION

## Modification du type de sélection



Soulever le récepteur  
ou bien



appuyer sur la touche vive-voix.



Appuyer sur la touche **PROGRAMMATION**.



Appuyer sur la touche \* pour la sélection DTMF.



Appuyer sur la touche # pour la sélection A DECADES.



Appuyer sur la touche **PROGRAMMATION**.



Raccrocher  
ou bien



appuyer sur la touche vive-voix.

## Programmation du volume de la sonnerie



Soulever le récepteur  
ou bien



appuyer sur la touche vive-voix.



Appuyer sur la touche **PROGRAMMATION**.



Appuyer sur la touche **5**. Le haut-parleur émet la mélodie de la sonnerie avec le niveau de volume précédemment programmé.

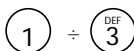

Appuyer sur les touches **1-3** pour fixer le volume désiré (voir chapitre CARACTERISTIQUES TECHNIQUES).



Appuyer de nouveau sur la touche **5** pour terminer la programmation.



Appuyer sur la touche **PROGRAMMATION**.



Raccrocher  
ou bien



appuyer sur la touche vive-voix.

# PROGRAMMATION

## Programmation de la tonalité de la sonnerie



Soulever le récepteur

ou bien



appuyer sur la touche vive-voix.



Appuyer sur la touche **PROGRAMMATION**.



Appuyer sur la touche **6**. Le haut-parleur émet la mélodie de la sonnerie avec le niveau de volume précédemment programmé.

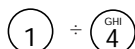

Appuyer sur les touches **1÷4** pour fixer la tonalité désirée (voir chapitre CARACTERISTIQUES TECHNIQUES).



Appuyer de nouveau sur la touche **6** pour terminer la programmation.



Appuyer sur la touche **PROGRAMMATION**.



Raccrocher  
ou bien



appuyer sur la touche vive-voix.

## Sélection du type d'appareil auquel le téléphone est raccordé pour les fonctions **PORTIER VIDEO**



Soulever le récepteur

ou bien



appuyer sur la touche vive-voix.



Appuyer sur la touche **PROGRAMMATION**.



Appuyer sur la touche **7**.



Appuyer sur la touche **1** si le téléphone est connecté à l'interface téléphonique **bpt**.



Appuyer sur la touche **2** si le téléphone est connecté à une centrale téléphonique PABX CT1/6 ou CT2/8.



Appuyer sur la touche **3** si le téléphone est connecté à une centrale téléphonique PABX CT1/6U, CT2/8U ou CT2/8E PABX.



Appuyer sur la touche **7** pour terminer la programmation.



Appuyer sur la touche **PROGRAMMATION**.



Raccrocher  
ou bien



appuyer sur la touche vive-voix.

---

# PROGRAMMATION

## Rétablissement de la configuration par défaut



Soulever le récepteur  
ou bien



appuyer sur la touche vive-voix.



Appuyer sur la touche  
**PROGRAMMATION**.



Appuyer deux fois sur la  
touche 0.



Appuyer sur la touche  
**PROGRAMMATION**.



Raccrocher  
ou bien



appuyer sur la touche vive-voix.

**ATTENTION.** Cette opération efface tous les numéros de téléphone mémorisés.

# CARACTERISTIQUES TECHNIQUES

- Fonctionnement avec vive-voix.
- Possibilité de mémoriser un numéro pour appel de service (20 chiffres maxi).
- Possibilité de mémoriser jusqu'à 10 numéros de téléphone (20 chiffres maxi par numéro).
- Répétition du dernier numéro composé.
- Sonnerie réglable avec 3 niveaux de volume (minimum, moyen, maximum).
- Tonalité de la sonnerie réglable avec 4 mélodies.
- Commandes de portier vidéo (ouvre-porte, appel concierge, commutation portier vidéo/téléphone, auxiliaire/minute-rie).
- Durée flash réglable: 1 = 100 ms, 2 = 120 ms, 3 = 300 ms, 4 = 600 ms.
- Durée de la pause réglable de 1 à 8 s: 1 = 1 s, ..., 8 = 8 s.
- Alimentation du téléphone: moyennant ligne urbaine ou interface téléphonique.
- Température de fonctionnement: de 0 °C à +35 °C.
- Humidité relative: 90% sans condensation.

## Moniteur blanc/noir IM/T

- Alimentation: 12÷24 Vca, 14÷24 Vcc.
- Consommation: 8 W.
- Tube: CRT 5" (12,5 cm) à 90°.
- Standard CCIR (EIA).
- Allumage en présence du signal vidéo.
- Impédance d'entrée vidéo: 100 Ω.
- Bande passante à -3 dB: 5 MHz.
- Fréquence horizontale: 15.625 Hz (15.750 Hz EIA).
- Fréquence verticale: 50 Hz (60 Hz EIA).

## Moniteur en couleurs IM/TC

- Standard PAL.
- Display: LCD couleurs 3,5" à matrice active de 112.320 points.
- Alimentation: 12÷16 Vca, 14÷18 Vcc.
- Consommation: 6 W maxi.
- Allumage en présence du signal vidéo.

- Impédance d'entrée vidéo: 100 Ω.
- Bande passante à -3 dB: 5 MHz.

L'appareil est homologué suivant les normes CTR 37 et CTR 38 et satisfait à la norme EN 60950 relative à la sécurité électrique et à la directive 89/336/EEC modifiée par la directive 93/68/EEC relative à la compatibilité électromagnétique.

Approbation européenne délivrée par le TÜV Rheinland Product Safety GmbH

**CE 0197 X**

# UTILISATION

## Appel



Soulever le récepteur.



Composer le numéro désiré.



En fin de conversation, raccrocher.

## Appel à vive-voix (avec le récepteur accroché)



Appuyer sur la touche vive-voix. La LED rouge s'allume.



Composer le numéro désiré.



En fin de conversation, appuyer de nouveau sur la touche vive-voix.

## Touche RP



Soulever le récepteur  
ou bien



appuyer sur la touche vive-voix.



Appuyer sur la touche **RP** pour répéter le dernier numéro composé.

## Touche MUTE



Appuyer sur la touche **MUTE** si, pendant une conversation téléphonique, vous souhaitez que l'interlocuteur n'écoute pas pour un temps ce que vous êtes en train de dire (microphone, récepteur et haut-parleur sont exclus).



Appuyer de nouveau sur la touche **MUTE** pour rétablir la conversation.

## Touche R (flash)



Cette touche peut être utilisée lorsque le moniteur-vidéo/téléphone est raccordé à une centrale téléphonique. Consulter la notice de la centrale pour connaître l'utilisation de la touche **R**.



# UTILISATION

## Touche de SERVICE

Appel d'un numéro de téléphone que vous composez souvent



Appuyer sur la touche de **SERVICE**.

Le téléphone se met en mode vive-voix et le numéro mémorisé est composé.

## Appel avec un indicatif



Appuyer sur la touche de **SERVICE**.

Le téléphone se met en mode vive-voix et l'indicatif mémorisé est composé.



Composer le numéro désiré.



Soulever le récepteur si vous voulez exclure la fonction vive-voix.

## Touche NUMEROS COURTS



Appuyer sur la touche **NUMEROS COURTS**.

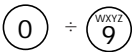

Appuyer sur la touche (0÷9) à laquelle vous avez associé le numéro de téléphone désiré.

## Touches de réglage du volume appel à vive-voix



En utilisant les touches **REGLAGE VOLUME** pendant la conversation en vive-voix, le volume du haut-parleur peut être augmenté ou diminué.

## Touches fonction PORTIER VIDEO



Auxiliaire/minuterie



Ouvre-porte



Mise en marche poste extérieur



Appel concierge



Commutation moniteur vidéo/téléphone

Les touches **OUVRE-PORTE** et **AUXILIAIRE/MINUTERIE** ne sont mises en service qu'après un appel ou une mise en marche automatique.

**NOTE.** Les fonctions portier vidéo s'effectuent uniquement lorsque le récepteur est soulevé ou en mode vive-voix.



# INDICE

Simbología .....	68	<b>Instrucciones para el usuario</b>	
<b>Instrucciones para el instalador</b>		Modo de empleo .....	80
Advertencias .....	70	- Llamada .....	80
Características generales .....	71	- Llamada manos libres	
Conexiones .....	72	(con auricular colgado) .....	80
Programación .....	73	- Tecla RP .....	80
- Configuración por defecto .....	73	- Tecla mute .....	80
- Programación código		- Tecla R (flash) .....	80
de llamada del aparato		- Tecla de servicio .....	81
conectado a la interfaz IT/300 .....	73	- Tecla números abreviados .....	81
- Memorización de los		- Tecla ajuste del volumen	
números abreviados .....	74	en modo manos libres .....	81
- Memorización de un número		- Teclas función videoportero .....	81
para llamadas de servicio .....	74		
- Programación de la duración			
del flash (tecla R) .....	75		
- Programación de la duración			
de la pausa .....	75		
- Modificación del tipo de selección .....	76		
- Programación			
del volumen del timbre .....	76		
- Programación			
de los tonos del timbre .....	77		
- Selección del tipo de aparato			
al que el teléfono se conectará para			
las funciones de videoportero .....	77		
- Reactivación de la			
configuración por defecto .....	78		
<b>Características técnicas .....</b>	<b>79</b>		



# SIMBOLOGIA

- |  |   |  |  |  |   |
|--|---|--|--|--|---|
|  |   |  | Teclado telefónico 12 teclas estándar  |  | Tecla autoactivación/ selección placa externa                 |
|  |   |  |  |  | Tecla auxiliar (!)  |
|  |   |  |  |  | Tecla de llamada conserje (!)                                 |
|  |   |  |  |  | Tecla de conmutación videopor- tero/teléfono multifunción (!) |
|  | Tecla R (flash)                                       |  |  | Tecla de servicio  |   |
|  | Tecla mute  |  |  | Ajuste brillo  |   |
|  | Tecla RP (repetición último número)                   |  |  | Ajuste contraste mod. IM/T y saturación color mod. IM/TC (!)   |   |
|  | Tecla de manos libres                                 |  | <b>LED</b>   | Indicador luminoso rojo en modalidad de manos libres. Durante la programación del teléfono el LED permanece encendido. |   |
|  | Tecla aumento volumen                                 |  | <b>(!) Teclas que se pueden utilizar si el aparato está conectado a un equipo de videoportero.</b> |  |   |
|  | Tecla reducción volumen                               |  |  |  |   |
|  | Tecla de programación                                 |  |  |  |   |
|  | Tecla números abreviados                              |  |  |  |   |
|  | Teclas utilizables para funciones auxiliares externas |  |  |  |   |
|  |   |  |  |  |   |
|  |   |  |  |  |   |
|  |   |  |  |  |   |
|  | Tecla abrepuerta (!)                                  |  |  |  |   |

---

# ADVERTENCIAS

Leer atentamente las advertencias incluidas en este manual ya que proporcionan indicaciones importantes con respecto a la seguridad de utilización, instalación y mantenimiento.

Después de haber desembalado el aparato, comprobar que está en perfectas condiciones.

Los elementos del embalaje (bolsas de plástico, espuma de poliestireno, etc.) no se deben dejar al alcance de los niños ya que representan potenciales fuentes de peligro.

La eliminación de los embalajes se debe realizar de acuerdo con las normas vigentes.

La ejecución de la instalación tiene que respetar las normas de seguridad en vigor.

**No pasar los cables telefónicos por el mismo recorrido que los cables eléctricos.**

Instalar el aparato en ambientes sin polvo, lejos de equipos que puedan generar perturbaciones eléctricas de alta frecuencia como: soldadores, motores eléctricos, hornos microondas, acondicionadores de aire, etc.

Este aparato se tiene que utilizar únicamente para el objetivo para el que ha sido diseñado; cualquier otro tipo de uso se considerará impropio y peligroso.

El fabricante no puede ser considerado responsable por posibles daños derivados de usos impropios, erróneos o irracionales. Si es necesario realizar alguna reparación, habrá que dirigirse únicamente a un centro de asistencia técnica autorizado por el fabricante.

Si no se respetan estas advertencias, se compromete gravemente la seguridad del aparato.

El instalador tendrá que asegurarse de que la información dirigida al usuario, donde esté prevista, se entregue junto a los aparatos.

Todos los aparatos que forman la instalación se tienen que utilizar únicamente para el objetivo para el que han sido diseñados.

---

# CARACTERISTICAS GENERALES

Videoportero-teléfono de sobremesa IM/T (IM/TC) completo de cable telefónico (2 m) para el enlace a la línea telefónica urbana.

Caja en ABS y pantalla gris.

El aparato permite la conexión, a través del interfaz telefónico IT/300, a redes telefónicas tanto de tipo decádico como de tipo multifrecuencia.

Dispone de función manos libres.

Cuenta con pulsadores especiales para utilizar de manera sencilla el sistema de videoportero 300 **bpt**, a través del correspondiente interfaz telefónico.

## Funciones

- Ajuste de volumen de la nota de llamada telefónica.
- Función manos libres.
- Compatibilidad con sistema decádico o multifrecuencia.
- Mandos de control para instalaciones de videoportero (para utilizar dichos mandos será necesario el uso del interfaz telefónico **bpt**).
- Se puede programar la duración de la pausa.
- Exploración de placas externas y/o cámaras suplementarias.
- Autoactivación.
- Mando apertura puerta.
- Llamada conserje.
- Mandos auxiliares.

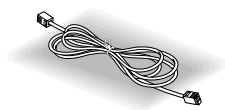

Cable telefónico

# CONEXIONES

## Conector CN1

Se utiliza para realizar la conexión entre el auricular y el aparato.

## Conector CN2

Se utiliza para realizar la conexión del aparato con la línea telefónica urbana.

**NOTA.** El aparato debe conectarse sólo con líneas telefónicas analógicas, no con líneas digitales ISDN.

## Conector CN3

Se utiliza para realizar la conexión del alimentador suplementario.

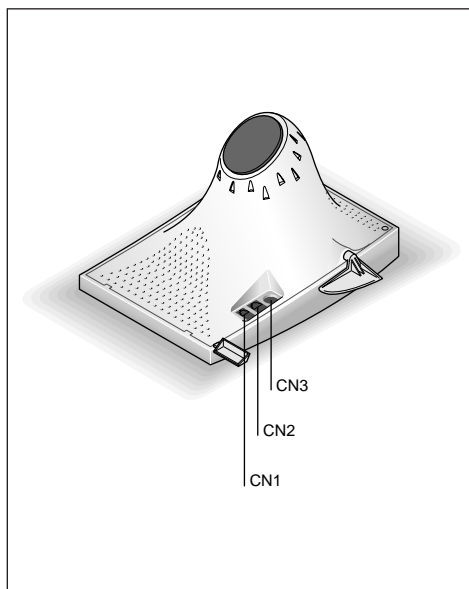



---

# PROGRAMACION

## Configuración por defecto

- Volumen de llamada: 3 (nivel máximo).
- Nota de llamada: melodía 1.
- Volumen manos libres: 3 (nivel máximo).
- Tipo de selección línea: DTMF.
- Duración pausa: 1 s.
- Pulsador R (flash): 100 ms.
- Teclas función videoportero: a utilizar con interfaz telefónico **bpt**.

Se puede entrar en modo programación, tanto con el microteléfono descolgado como desde la modalidad manos libres.

La entrada en modo programación se indica mediante el encendido del LED rojo y por la ausencia de señal de línea.

Para la programación de más funciones no es necesario salir y volver a entrar en el modo programación.

*Durante la programación, cada vez que se pulse una tecla se oirá un breve sonido, la memorización de los datos producirá un sonido más largo y, los errores un timbre prolongado.*

**ADVERTENCIA.** Si la programación se realiza durante una conexión con la línea urbana, una vez pasado un minuto, la acción de disuasión de la centralita, puede molestar la continuación de la programación.

En este caso se aconseja colgar el microteléfono y seguir con la programación a partir del momento de la interrupción.

## Programación código de llamada del aparato conectado a la interfaz IT/300

El aparato, una vez conectado con su interfaz telefónica, debe ser programado según el procedimiento descrito en las instrucciones de la interfaz IT/300.

# PROGRAMACION

## Memorización de los números abreviados



Descolgar el auricular

o



pulsar la tecla manos libres.



Pulsar la tecla **PROGRAMACION**.



Pulsar la tecla **NUMEROS ABREVIADOS**.

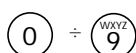

Pulsar la tecla correspondiente al número en el que se quiere memorizar (0-9).



Marcar el número telefónico deseado (máx. 20 cifras) (\*).



Pulsar la tecla **NUMEROS ABREVIADOS** para memorizar.



Pulsar la tecla **PROGRAMACION**.



Colgar el auricular

o



pulsar la tecla manos libres.

Repetir la operación para memorizar el siguiente número. Se pueden memorizar hasta un máximo de 10 números.

(\*) Si el teléfono está conectado a una centralita, será necesario introducir una pausa entre el 0 (número para obtener la línea urbana) y el número telefónico.

Para introducir una pausa pulsar la tecla **RP**: ej. **0 RP 0123 456789**.

La duración de la pausa se puede duplicar si se pulsa dos veces la tecla **RP**.

## Memorización de un número para llamada de servicio

Este tipo de programación puede ser útil, por ejemplo, para llamar a un número telefónico de uso frecuente, o para evitar marcar números repetitivos como el prefijo urbano o el prefijo de otra red de telefonía fija.



Descolgar el auricular

o



pulsar la tecla manos libres.



Pulsar la tecla **PROGRAMACION**.



Pulsar la tecla **SERVICIO**.



Marcar el número telefónico deseado (máx. 20 cifras) (\*).



Pulsar la tecla **SERVICIO** para memorizar.



Pulsar la tecla **PROGRAMACION**.



Colgar el auricular

o



pulsar la tecla manos libres.

(\*) Si el teléfono está conectado a una centralita, será necesario introducir una pausa entre el 0 (número para obtener la línea urbana) y el número telefónico.

Para introducir una pausa pulsar la tecla **RP**: ej. **0 RP 0123 456789**.

La duración de la pausa se puede duplicar si se pulsa dos veces la tecla **RP**.

# PROGRAMACION

## Programación de la duración del flash (tecla R)



Descolgar el auricular

o



pulsar la tecla manos libres.



Pulsar la tecla **PROGRAMACION**.



Pulsar la tecla **R**.

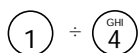

Pulsar la tecla correspondiente al número de la duración que se desea memorizar (1÷4) (véase capítulo CARACTERISTICAS TECNICAS).



Pulsar la tecla **R** para memorizar.



Pulsar la tecla **PROGRAMACION**.



Colgar el auricular

o



pulsar la tecla manos libres.

## Programación de la duración de la pausa



Descolgar el auricular

o



pulsar la tecla manos libres.



Pulsar la tecla **PROGRAMACION**.



Pulsar la tecla **RP**.

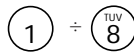

Pulsar la tecla correspondiente al número de la duración que se desea memorizar (1÷8) (véase capítulo CARACTERISTICAS TECNICAS).



Pulsar la tecla **RP** para memorizar.



Pulsar la tecla **PROGRAMACION**.



Colgar el auricular

o



pulsar la tecla manos libres.

# PROGRAMACION

## Modificación del tipo de selección



Descolgar el auricular

o



pulsar la tecla manos libres.



Pulsar la tecla **PROGRAMACION**.



Pulsar la tecla \* para la selección DTMF.



Pulsar la tecla # para la selección DECADICA.



Pulsar la tecla **PROGRAMACION**.



Colgar el auricular

o



pulsar la tecla manos libres.

## Programación del volumen del timbre



Descolgar el auricular

o



pulsar la tecla manos libres.



Pulsar la tecla **PROGRAMACION**.



Pulsar la tecla **5**. Empezará a sonar la melodía del timbre con el volumen anteriormente programado.

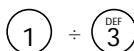

Pulsar las teclas **1+3** para fijar el volumen deseado (véase capítulo **CARACTERISTICAS TECNICAS**).



Volver a pulsar la tecla **5** para finalizar la programación.



Pulsar la tecla **PROGRAMACION**.



Colgar el auricular

o



pulsar la tecla manos libres.

# PROGRAMACION

## Programación de los tonos del timbre



Descolgar el auricular

o



pulsar la tecla manos libres.



Pulsar la tecla **PROGRAMACION**.



Pulsar la tecla **6**. Empezará a sonar la melodía del timbre con el volumen anteriormente programado.

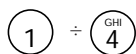

Pulsar las teclas **1+4** para fijar el tono deseado (véase capítulo **CARACTERISTICAS TECNICAS**).



Volver a pulsar la tecla **6** para finalizar la programación.



Pulsar la tecla **PROGRAMACION**.



Colgar el auricular

o



pulsar la tecla manos libres.

## Selección del tipo de aparato al que el teléfono se conectará para las funciones de **VIDEOPORTERO**



Descolgar el auricular

o



pulsar la tecla manos libres.



Pulsar la tecla **PROGRAMACION**.



Pulsar la tecla **7**.



Pulsar la tecla **1** si el teléfono está conectado con el interfaz telefónico **bpt**.



Pulsar la tecla **2** si el teléfono está conectado con una centralita telefónica PABX CT1/6 o CT2/8.



Pulsar la tecla **3** si el teléfono está conectado con una centralita telefónica PABX CT1/6U, CT2/8U o CT2/8E.



Volver a pulsar la tecla **7** para finalizar la programación.



Pulsar la tecla **PROGRAMACION**.



Colgar el auricular

o



pulsar la tecla manos libres.

---

# PROGRAMACION

## Reactivación de la configuración por defecto



Descolgar el auricular

o



pulsar la tecla manos libres.



Pulsar la tecla **PROGRA-**  
**MACION.**



Pulsar dos veces la tecla 0.



Pulsar la tecla **PROGRA-**  
**MACION.**



Colgar el auricular

o



pulsar la tecla manos libres.

**ATENCIÓN.** Con esta operación se cancelan todos los números telefónicos memorizados.

# CARACTERISTICAS TECNICAS

- Función manos libres.
  - Posibilidad de memorizar un número para llamada de servicio (máx. 20 cifras).
  - Posibilidad de memorizar hasta 10 números telefónicos (máx. 20 cifras por número).
  - Repetición del último número marcado.
  - Ajuste de volumen de timbre de llamada a 3 niveles (mínimo, medio, máximo).
  - Ajuste de tono de timbre de llamada: 4 melodías.
  - Mandos de control videoportero (abrepuerta, llamada conserje, conmutación videoportero/teléfono multifunción, auxiliar/luz escalera).
  - Ajuste duración del flash: 1 = 100 ms, 2 = 120 ms, 3 = 300 ms, 4 = 600 ms.
  - Ajuste duración pausa de 1 a 8 s: 1 = 1 s, ..., 8 = 8 s.
  - Alimentación teléfono: de la línea urbana o del interfaz telefónico.
  - Temperatura de funcionamiento: de 0 °C a +35 °C.
  - Humedad relativa: 90% sin condensación.
- Encendido ante presencia de señal vídeo.
  - Impedancia de entrada vídeo: 100  $\Omega$ .
  - Banda pasante a -3 dB: 5 MHz.

El aparato está homologado según las normas CTR 21 y cumple con la norma EN 60950, relativa a la seguridad eléctrica y con la directiva 89/336/EEC modificada con la 93/68/EEC, relativas a la compatibilidad electromagnética.

Aprobación europea expedida por TÜV Rheinland Product Safety GmbH

## CE 0197 X

### Monitor b/n IM/T

- Alimentación: 12÷24 Vca, 14÷24 Vcc.
- Absorción: 8 W.
- Cinescopio: CRT 5" (12,5 cm) a 90°.
- Estándar CCIR (EIA).
- Encendido ante presencia de señal vídeo.
- Impedancia de entrada vídeo: 100  $\Omega$ .
- Banda pasante a -3 dB: 5 MHz.
- Frecuencia horizontal: 15.625 Hz (15.750 Hz EIA).
- Frecuencia vertical: 50 Hz (60 Hz EIA).

### Monitor color IM/TC

- Estándar PAL.
- Display: LCD de colores 3,5" de matriz activa die 112.320 puntos.
- Alimentación: 12÷16 Vca, 14÷18 Vcc.
- Absorción: máx. 6 W.

# MODO DE EMPLEO

## Llamada



Descolgar el auricular.



Marcar el número deseado.



Una vez terminada la conversación, colgar el auricular.

## Tecla MUTE



Pulsar la tecla **MUTE** si durante la conversación telefónica se desea impedir, temporalmente, que el interlocutor escuche (micrófono, auricular y altavoz se desactivan).



Pulsar de nuevo la tecla **MUTE** para retomar la conversación.

## Llamada manos libres (con auricular colgado)



Pulsar la tecla manos libres. Se encenderá el LED rojo.



Marcar el número deseado.



Una vez terminada la conversación, volver a pulsar la tecla manos libres.

## Tecla R (flash)



Esta tecla se puede utilizar cuando el monitor con teléfono está conectado a una centralita telefónica.

Consultar el manual de instrucciones para conocer la utilización de la tecla **R**.

## Tecla RP



Descolgar el auricular

o



pulsar la tecla manos libres.



Pulsar la tecla **RP** para que repita el último número marcado.



# MODO DE EMPLEO

## Tecla de SERVICIO

Llamada a un número telefónico de uso frecuente



Pulsar la tecla **SERVICIO**. El teléfono se activa en modalidad manos libres y se marca automáticamente el número memorizado.

## Tecla ajuste del volumen en modo manos libres



Si se utilizan las teclas **AJUSTE DE VOLUMEN** durante la conversación en función manos libres, el volumen del altavoz se puede aumentar o disminuir.

## Llamada con prefijo



Pulsar la tecla **SERVICIO**. El teléfono se activa en modalidad manos libres y se marca automáticamente el prefijo memorizado.



Marcar el número deseado.



Descolgar el auricular si se desea desactivar la función manos libres.

## Teclas función VIDEOPORTERO



Auxiliar/Luz escalera



Abrepuerta



Activación placa externa



Llamada conserje



Conmutación videoportero/teléfono multifunción

## Tecla NUMEROS ABREVIADOS



Pulsar la tecla **NUMEROS ABREVIADOS**.

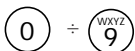

Pulsar la tecla (**0÷9**) que corresponde al número telefónico deseado.

Los botones **ABREPUERTA** y **AUXILIAR/LUZ ESCALERAS** están habilitados sólo en caso de llamada o de autoactivación.

*NOTA. Las funciones de videoportero están permitidas sólo con el auricular descolgado o en modalidad manos libres.*









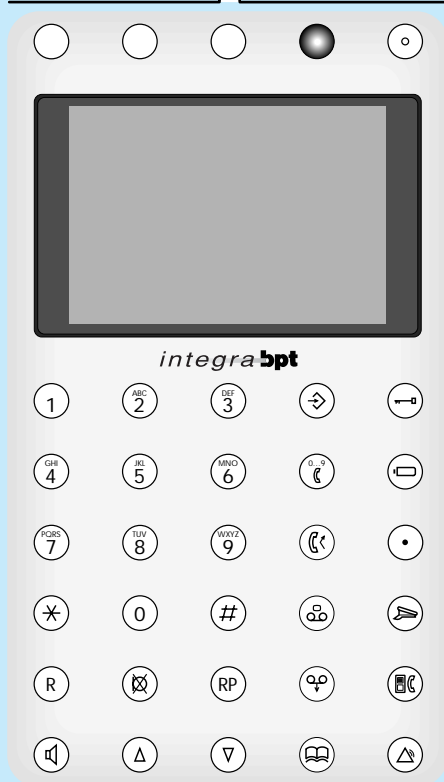
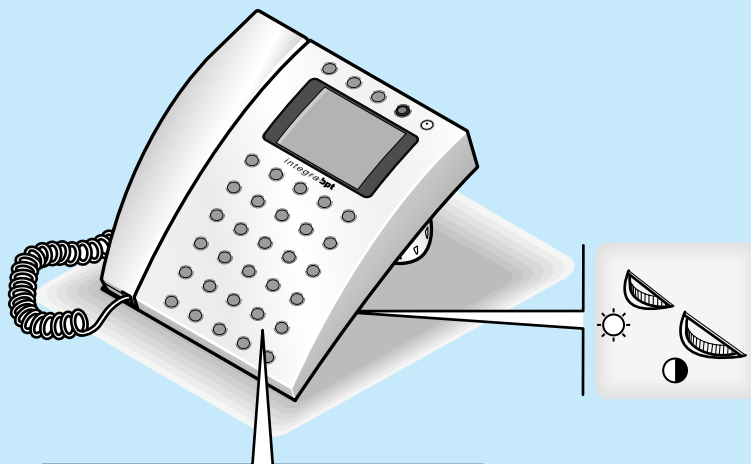

























# INDICE

Simbologia . . . . .	84	<b>Instruções para o utente</b>	
<b>Instruções para o instalador</b>		<b>Utilização . . . . .</b>	<b>96</b>
Advertências . . . . .	86	- Chamada . . . . .	96
Generalidade . . . . .	87	- Chamada viva voz	
Ligações . . . . .	88	(com auscultador no suporte) . . . . .	96
<b>Programação . . . . .</b>	<b>89</b>	- Tecla RP . . . . .	96
- Configuração de default . . . . .	89	- Tecla mute . . . . .	96
- Programação códigos		- Tecla R (flash) . . . . .	96
de chamada do aparelho		- Tecla de serviço . . . . .	97
ligado à interface IT/300 . . . . .	89	- Tecla números breves . . . . .	97
- Memorização dos números breves . . . . .	90	- Teclas regulação	
- Memorização de um número		do volume em viva voz . . . . .	97
para chamada de serviço . . . . .	90	- Tecla função videoporteiro . . . . .	97
- Programação da duração			
do flash (tecla R) . . . . .	91		
- Programação da duração			
da pausa . . . . .	91		
- Modificação do tipo de selecção . . . . .	92		
- Programação do volume			
do dispositivo acústico . . . . .	92		
- Programação da tonalidade			
do dispositivo acústico . . . . .	93		
- Selecção do tipo de aparelhagem			
com o qual o telefone está ligado			
para as funções videoporteiro . . . . .	93		
- Restabelecimento			
da configuração de default . . . . .	94		
<b>Características técnicas . . . . .</b>	<b>95</b>		

# SIMBOLOGIA



# SIMBOLOGIA

			Teclado telefónico 12 teclas standard		Tecla de inserção automática/ selecção da placa botoneira
					Tecla auxiliar (!)
					Tecla de chamada porteiro (!)
					Tecla de comutação videoporteiro/telefone (!)
	Tecla R (flash)			Tecla de serviço	
	Tecla mute			Regulação da luminosidade	
	Tecla RP (repetição do último número)			Regulação do contraste mod. IM/T e saturação de cor mod. IM/TC (!)	
	Tecla viva voz		<b>LED</b>	Sinalizador luminoso vermelho de modalidade viva voz. Durante a programação do telefone o LED está aceso.	
	Tecla incremento volume				
	Tecla decremento volume				
	Tecla de programação				
	Tecla números breves				
	Teclas utilizáveis para funções auxiliares externas				
					
					
					
					
	Tecla abertura porta (!)				

(!) Teclas utilizáveis se o aparelho está ligado a instalações videoporteiro.

---

# ADVERTÊNCIAS

Ler com atenção as advertências contidas no seguinte manual porque fornecem importantes indicações que dizem respeito à segurança do uso, da instalação e manutenção.

Depois de ter tirado a embalagem certificar-se da integridade do aparelho.

Os elementos da embalagem (sacos de plástica, poliestireno expando, etc.) não devem ser deixados ao alcance das crianças porque constituem potenciais fontes de perigo.

A eliminação das embalagens deve ser efectuada no respeito das normas vigentes. A execução da instalação deve corresponder às normas de segurança vigentes.

**Não passar os cabos telefónicos em percursos comuns aqueles dos cabos eléctricos.**

Instalar o aparelho em ambientes não poeirosos, longe de aparelhagens que possam gerar distúrbios eléctricos de alta frequência, tais como soldadoras, motores eléctricos, fornos a micro-ondas, condicionadores de ar, etc.

Este aparelho deverá ser destinado unicamente ao uso para o qual foi expressamente concebido; qualquer uso diverso é considerado impróprio e perigoso.

O fabricante não pode ser considerado responsável por eventuais danos que derivam de usos impróprios, erróneos e irracionais.

Para a eventual reparação dirigir-se somente a um centro de assistência técnica autorizado pelo fabricante.

O não respeito de quanto acima pode comprometer a segurança do aparelho.

O instalador deve certificar-se que as informações para o utente, onde previsto, estejam presentes sobre os aparelhos.

Todos os aparelhos que fazem parte do equipamento devem ser destinados exclusivamente para o uso para os quais foram concebidos.

---

# GENERALIDADE

Videoproteiro com telefone de mesa IM/T (IM/TC) completo de cabo telefónico (2 m) para a ligação à linha telefónica urbana.

Caixa em ABS e écran de vidro fumado.

O aparelho permite a conexão, através da interface telefónica IT/300, a redes telefónicas seja de tipo decádico, quer seja de tipo multifrequência.

Está dotado da função viva voz.

O aparelho está dotado de botões dedicados para inter-agir em modo simples com o sistema videoproteiro 300 **bpt** através da oportuna interface telefónica.

## Funções

- Volume nota de chamada telefónica regulável.
- Função viva-voz.
- Compatibilidade com o sistema "decádico" ou multifrequência.
- Comandos para instalações videoproteiro (para a actuação destes comandos é necessário o uso da interface telefónica **bpt**).
- Duração da pausa programável.
- Escanção das placas botoneiras e/ou câmaras de vídeo suplementares.
- Inserção automática.
- Comando abertura porta.
- Chamada proteiro.
- Comandos auxiliares.



Cabo telefónico

---

# LIGAÇÕES

## Conector CN1

É utilizado para efectuar a ligação entre o auscultador e o aparelho.

## Conector CN2

É utilizado para efectuar a ligação do aparelho à linha telefónica.

**NOTA.** O aparelho só deve ser ligado a linhas telefónicas analógicas, não a linhas digitais ISDN.

## Conector CN3

É utilizado para ligar o alimentador suplementar.

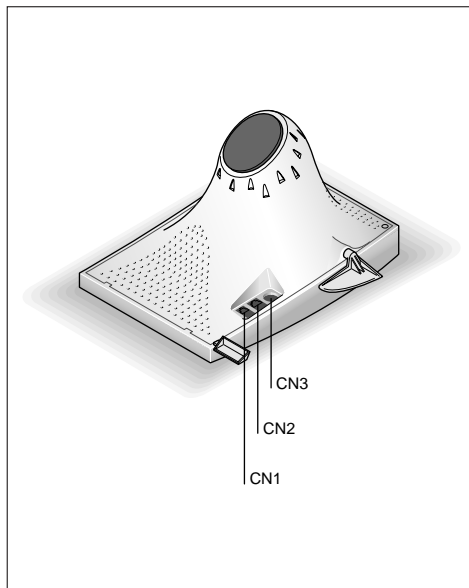



---

# PROGRAMAÇÃO

## Configuração de default

- Volume de chamada: 3 (nível máximo).
- Nota de chamada: melodia 1.
- Volume viva voz: 3 (nível máximo).
- Tipo de selecção linha: DTMF.
- Duração da pausa: 1 s.
- Botão R (flash): 100 ms.
- Teclas função videoproteiro: utilizáveis com a interface telefónica **bpt**.

Pode-se entrar no modo programação, seja com auscultador levantado que na modalidade viva voz.

A entrada na programação é sinalizada pelo LED vermelho e pela ausência do sinal de linha.

Para a programação de outras funções não é necessário sair e tornar a entrar da modalidade programação.

*Durante a programação a pressão das teclas é acompanhada por um som breve, a memorização dos dados por um som mais longo, os erros por um som prolongado.*

**ADVERTÊNCIA.** Se a programação for efectuada durante a ligação com a linha urbana, cerca de um minuto depois a acção de dissuasão da central pode perturbar a continuação da programação.

Neste caso tornar a colocar o auscultador no suporte e retomar a programação do ponto interrompido.

## Programação códigos de chamada do aparelho ligado à interface IT/300

Depois de ligado à própria interface telefónica o aparelho, deve ser programado com o procedimento referido nas instruções da interface IT/300.

# PROGRAMAÇÃO

## Memorização dos números breves



Levantar o auscultador  
ou então



premir a tecla viva voz.



Premir a tecla **PROG-  
MAÇÃO**.



Premir a tecla **NUMEROS  
BREVES**.

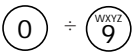

Premir a tecla com a qual é  
associado o número telefó-  
nico (0÷9).



Marcar o número desejado  
(máximo 20 cifras) (\*).



Premir a tecla **NUMEROS  
BREVES** para memorizar.



Premir a tecla **PROG-  
MAÇÃO**.



Tornar a colocar no suporte  
o auscultador  
ou então



premir a tecla viva voz.

Repetir a operação para memorizar o número sucessivo. Podem-se memorizar até 10 números.

*(\*) Se o telefone está ligado a uma central é necessário inserir uma pausa entre o 0 (número para a passagem à linha urbana) e o número telefónico.*

*Para inserir uma pausa premir a tecla RP:  
es. 0 RP 0123 456789.*

*A duração da pausa pode ser duplicada  
premindu duas vezes a tecla RP.*

## Memorização de um número para chamada de serviço

Esta programação pode ser útil, por exemplo, para chamar um número telefónico de uso frequente, ou então para evitar de marcar números repetitivos, tais como o indicativo urbano ou de outra rede de telefonia fixa.



Levantar o auscultador  
ou então



premir a tecla viva voz.



Premir a tecla **PROG-  
MAÇÃO**.



Premir a tecla de **SERVIÇO**.



Marcar o número desejado  
(máximo 20 cifras) (\*).



Premir a tecla de **SERVIÇO**  
para memorizar.



Premir a tecla **PROG-  
MAÇÃO**.



Tornar a colocar no suporte  
o auscultador  
ou então



premir a tecla viva voz.

*(\*) Se o telefone está ligado a uma central é necessário inserir uma pausa entre o 0 (número para a passagem à linha urbana) e o número telefónico.*

*Para inserir uma pausa premir a tecla RP:  
es. 0 RP 0123 456789.*

*A duração da pausa pode ser duplicada  
premindu duas vezes a tecla RP.*

# PROGRAMAÇÃO

## Programação da duração do flash (tecla R)



Levantar o auscultador  
ou então



premir a tecla viva voz.



Premir a tecla **PROGRA-  
MAÇÃO**.



Premir a tecla **R**.

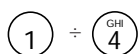

Premir o número relativo à  
duração que se entende pro-  
gramar (1÷4) (ver capítulo  
CARACTERISTICAS TECNI-  
CAS).



Premir **R** para memorizar.



Premir a tecla **PROGRA-  
MAÇÃO**.



Tornar a colocar no suporte  
o auscultador  
ou então



premir a tecla viva voz.

## Programação da duração da pausa



Levantar o auscultador  
ou então



premir a tecla viva voz.



Premir a tecla **PROGRA-  
MAÇÃO**.



Premir a tecla **RP**.

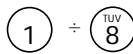

Premir o número relativo à  
duração que se entende pro-  
gramar (1÷8) (ver capítulo  
CARACTERISTICAS TECNI-  
CAS).



Premir **RP** para memorizar.



Premir a tecla **PROGRA-  
MAÇÃO**.



Tornar a colocar no suporte  
o auscultador  
ou então



premir a tecla viva voz.

# PROGRAMAÇÃO

## Modificação do tipo de selecção



Levantar o auscultador  
ou então



premir a tecla viva voz.



Premir a tecla **PROGRA-  
MAÇÃO**.



Premir a tecla \* para a  
selecção DTMF.



Premir a tecla # para a  
selecção DECADICA.



Premir a tecla **PROGRA-  
MAÇÃO**.



Tornar a colocar no suporte  
o auscultador  
ou então



premir a tecla viva voz.

## Programação do volume do dispositivo acústico



Levantar o auscultador  
ou então



premir a tecla viva voz.



Premir a tecla **PROGRA-  
MAÇÃO**.



Premir a tecla **5**. E' emitida  
pelo antifalante a melodia  
do dispositivo acústico com  
o nível do volume preceden-  
temente programado.

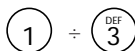

Premir as teclas **1÷3** para  
estabalacer o volume  
desejado (ver capítulo CA-  
RACTERISTICAS TECNI-  
CAS).



Premir novamente a tecla **5**  
para terminar a progra-  
mação.



Premir a tecla **PROGRA-  
MAÇÃO**.



Tornar a colocar no suporte  
o auscultador  
ou então



premir a tecla viva voz.

# PROGRAMAÇÃO

## Programação da tonalidade do dispositivo acústico



Levantar o auscultador  
ou então



premir a tecla viva voz.



Premir a tecla **PROGRA-  
MAÇÃO**.



Premir a tecla **6**. É emitida pelo antialante a melodia do dispositivo acústico com o nível do volume precedentemente programado.

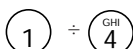

Premir as teclas **1÷4** para estabelecer a tonalidade desejada (ver capítulo **CARACTERÍSTICAS TÉCNICAS**).



Premir novamente a tecla **6** para terminar a programação.



Premir a tecla **PROGRA-  
MAÇÃO**.



Tornar a colocar no suporte o auscultador

ou então



premir a tecla viva voz.

## Seleção do tipo de aparelhagem com o qual o telefone está ligado para as funções **VIDEOPORTEIRO**



Levantar o auscultador  
ou então



premir a tecla viva voz.



Premir a tecla **PROGRA-  
MAÇÃO**.



Premir a tecla **7**.



Premir a tecla **1** se o telefone está ligado com a interface telefónica **bpt**.



Premir a tecla **2** se o telefone está ligado com uma central telefónica PABX CT1/6 ou CT2/8.



Premir a tecla **3** se o telefone está ligado com uma central telefónica PABX CT1/6U, CT2/8U ou CT2/8E.



Premir a tecla **7** para terminar a programação.



Premir a tecla **PROGRA-  
MAÇÃO**.



Tornar a colocar no suporte o auscultador

ou então



premir a tecla viva voz.

---

# PROGRAMAÇÃO

## Restabelecimento da configuração de default



Levantar o auscultador  
ou então



premir a tecla viva voz.



Premir a tecla **PROGRA-  
MAÇÃO**.



0.

Premir duas vezes a tecla



Premir a tecla **PROGRA-  
MAÇÃO**.



Tornar a colocar no suporte  
o auscultador  
ou então



premir a tecla viva voz.

**ATENÇÃO.** Com esta operação se anulam todos os números telefónicos memorizados.

# CARACTERÍSTICAS TÉCNICAS

- Funcionamento viva voz.
  - Possibilidade de memorizar um número para chamada de serviço (20 cifras máx.).
  - Possibilidade de memorizar até 10 números telefónicos (20 cifras máx. por número).
  - Repetição do último número marcado.
  - Dispositivo acústico regulável em volume com 3 níveis (mínimo, médio, máximo).
  - Dispositivo acústico regulável na tonalidade com 4 melodias.
  - Comandos videoporteiro (abertura da porta, chamada porteiro, comutação videoporteiro/telefone, auxiliar/luz escadas).
  - Duração flash regulável: 1 = 100 ms, 2 = 120 ms, 3 = 300 ms, 4 = 600 ms.
  - Duração da pausa regulável desde 1 até 8 s: 1 = 1 s, ..., 8 = 8 s.
  - Alimentação telefone: da linha urbana ou da interface telefónica.
  - Temperatura de funcionamento: desde 0 °C até +35 °C.
  - Humidade relativa: 90% sem condensação.
- Liga-se na presença do sinal vídeo.
  - Impedância de entrada vídeo: 100 Ω.
  - Banda passante a -3 dB: 5 MHz.

O aparelho foi homologado segundo as normas CTR 37 e CTR 38 e satisfaz a norma EN 60950, relativa à segurança eléctrica, e a directiva 89/336/EEC modificada com 93/68/EEC, relativas à compatibilidade electromagnética.

Aprovação europeia passada pelo TÜV Rheinland Product Safety GmbH

## CE 0197 X

### Monitor b/p IM/T

- Alimentação: 12÷24 Vca, 14÷24 Vcc.
- Consumo: 8 W.
- Cinescópico: CRT 5" (12,5 cm) a 90°.
- Standard vídeo: CCIR (EIA).
- Liga-se na presença do sinal vídeo.
- Impedância de entrada vídeo: 100 Ω.
- Banda passante a -3 dB: 5 MHz.
- Frequência horizontal: 15.625 Hz (15.750 Hz EIA).
- Frequência vertical: 50 Hz (60 Hz EIA).

### Monitor a cores IM/TC

- Standard vídeo: PAL.
- Display: LCD cor 3,5" com matriz de 112.320 pontos.
- Alimentação: 12÷16 Vca, 14÷18 Vcc.
- Consumo: máx. 6 W.

# UTILIZAÇÃO

## Chamada



Levantar o auscultador.



Marcar o número desejado.



Ao fim da conversação, tornar a colocar o auscultador no suporte.

## Chamada viva voz (com auscultador no suporte)



Premir a tecla viva voz.



Marcar o número desejado.



Ao fim da conversação, tornar a premir a tecla viva voz.

## Tecla RP



Levantar o auscultador  
ou então



premir a tecla viva voz.



Premir a tecla **RP** para efectuar a repetição do último número marcado.

## Tecla MUTE



Premir a tecla **MUTE** se durante uma conversação telefónica se deseja impedir temporariamente a audição por parte do interlocutor (microfone, auscultador e altifalante podem ser desactivados).



Premir novamente a tecla **MUTE** para restabelecer a conversação.

## Tecla R (flash)



Esta tecla pode ser utilizada quando o telefone está ligado a uma central telefónica. Consultar o manual de instruções da central utilizada para conhecer a utilização da tecla **R**.



# UTILIZAÇÃO

## Tecla de SERVIÇO

Chamada a um número telefónico de utilização frequente



Premir a tecla **SERVIÇO**. O telefone se coloca em modalidade viva voz e é enviado o número memorizado.

## Chamada através do indicativo



Premir a tecla **SERVIÇO**. O telefone se coloca em modalidade viva voz e é enviado o indicativo memorizado.



Marcar o número desejado.



Levantar o auscultador se se deseja excluir a função viva voz.

## Tecla NUMEROS BREVES



Premir a tecla **NUMEROS BREVES**.

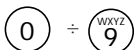

Premir a tecla (0÷9) à qual foi associado o número telefónico desejado.

## Tecla regulação do volume em viva voz



Utilizando as teclas **REGULAÇÃO VOLUME** durante a conversação a viva voz, o volume do altifalante pode ser aumentado ou diminuído.

## Teclas função VIDEOPORTEIRO



Auxiliar/Luz escadas



Abertura porta



Inserção placa botoneira



Chamada porteiro



Comutação videoporteiro/telefone

As teclas de **ABERTURA DA PORTA** e **AUXILIAR/LUZ ESCADAS** se habilitam só a seguir a uma chamada ou inserção automática.

*NOTA. As funções videoporteiro são consentidas só com o auscultador levantando ou na modalidade viva voz.*



---

