IT/300

INTERFACCIA TELEFONICA
TELEPHONE INTERFACE
TELEFONSCHNITTSTELLE
INTERFACE TELEPHONIQUE
INTERFAZ TELEFONICO
INTERFACE TELEFONICA

ISTRUZIONI

INSTRUCTIONS

ANLEITUNG

INSTRUCTIONS

INSTRUCCIONES

INSTRUÇÕES

ITALIANO

ENGLISH

DEUTSCH

FRANÇAIS

ESPAÑOL

PORTUGUÊS

INDICE

Istruzioni per l'installatore

Generalità	4
Avvertenze	5
Installazione	6
Collegamenti	7
Programmazione	8
- Configurazione di default	8
- Ingresso ed uscita dalle operazioni di programmazione	8
- Programmazione codice di identificazione da telefono	8
- Programmazione codice di identificazione da alimentatore	9
- Modalità riconoscimento flash	9
- Intercettazione flash	10
- Ripristino della configurazione di default	10
Caratteristiche tecniche	11
Toni e ritmi	12
- Toni di segnalazione	12
- Ritmi di chiamata	12

Istruzioni per l'utente

Glossario	13
Funzioni	14
- Chiamata su linea urbana	14
- Risposta alle chiamate in arrivo	14
- Risposta a chiamata da posto esterno ed apertura della porta	14
- Autoinserimento su posto esterno	15
- Cambio interlocutore	15
- Chiamata portiere	15
- Comando ausiliario/luce scale da telefono	16
- Disabilitazione avviso acustico di chiamata in arrivo	16
- Accesso ai servizi Telecom DTMF	16
- Funzioni ottenibili con l'utilizzo del telefono bpt e con telefoni standard	17

GENERALITÀ

L'interfaccia telefonica permette il collegamento di un apparecchio telefonico alla linea videocitfonica e citfonica serie 300. Permette l'utilizzo, oltre al telefono **bpt**, di normali apparecchi telefonici decadici o DTMF, cordless, segreteria telefonica, modem, ecc. Per impianti videocitfonici, gli apparecchi telefonici non **bpt** devono essere collegati tramite un filtro separatore.

L'apparecchio consente anche di inviare chiamate ad un centralino di portineria e di comandare l'apriporta, luci scale centralizzato, ecc.

L'apparecchio é realizzato in un contenitore DIN a 8 moduli.

Funzioni base

- Accesso diretto alla linea urbana.
- Collegamento al sistema videocitfonico serie 300 con funzione di autoinserimento.
- Collegamento al sistema citfonico con segreto di conversazione.
- Comunicazione telefonica anche in mancanza di alimentazione da rete.
- Chiamata diversificata da posto esterno, centralino di portineria e linea telefonica.
- Messa in attesa comunicazione (urbana/citfonica).
- Protezione linea telefonica.
- Programmazione dell'apparecchio mediante telefono.
- Alimentazione da rete elettrica.

AVVERTENZE

Leggere attentamente le avvertenze contenute nel seguente manuale in quanto forniscono importanti indicazioni riguardanti la sicurezza d'uso, d'installazione e manutenzione.

Dopo aver tolto l'imballaggio assicurarsi dell'integrità dell'apparecchio.

Gli elementi dell'imballaggio (sacchetti in plastica, polistirolo espanso, ecc.) non devono essere lasciati alla portata dei bambini in quanto potenziali fonti di pericolo.

Lo smaltimento degli imballi deve essere effettuato nel rispetto delle norme vigenti.

L'esecuzione dell'impianto deve essere rispondente alle norme di sicurezza vigenti.

Non far passare i cavi telefonici in percorsi comuni a quelli dei cavi elettrici.

Installare il centralino in ambienti non polverosi, lontano da apparecchiature che possono generare disturbi elettrici di alta frequenza quali saldatrici, motori elettrici, forni a microonde, condizionatori d'aria, ecc.

E' opportuno prevedere a monte dell'alimentatore un appropriato interruttore di sezionamento e protezione.

Prima di collegare l'apparecchio accertarsi che i dati di targa siano rispondenti a quelli della rete di distribuzione.

Questo apparecchio dovrà essere destinato unicamente all'uso per il quale è stato espressamente concepito; qualunque uso diverso è da considerarsi improprio e pericoloso.

Il costruttore non può essere considerato responsabile per eventuali danni derivanti da usi impropri, erronei ed irragionevoli.

Prima di effettuare qualunque operazione di pulizia o di manutenzione, disinserire l'apparecchio dalla rete di alimentazione elettrica, aprendo l'interruttore dell'impianto.

In caso di guasto e/o cattivo funzionamento dell'apparecchio, scollegarlo dall'alimentazione e non manometterlo.

Per l'eventuale riparazione rivolgersi solamente ad un centro di assistenza tecnica autorizzato dal costruttore.

Il mancato rispetto di quanto sopra può compromettere la sicurezza dell'apparecchio.

L'installatore deve assicurarsi che le informazioni per l'utente, dove previste, siano presenti sugli apparecchi.

Tutti gli apparecchi costituenti l'impianto devono essere destinati esclusivamente per l'uso per cui sono stati concepiti.

INSTALLAZIONE

L'apparecchio, realizzato in un contenitore da 8 unità basso, può essere installato senza coprimorsetti in scatole munite di guida DIN (EN 50022).

Per le dimensioni di ingombro vedere la fig. 1A.

Oppure può essere installato a parete, con coprimorsetti, utilizzando la guida DIN in dotazione.

Per le dimensioni d'ingombro vedere la fig. 1B.

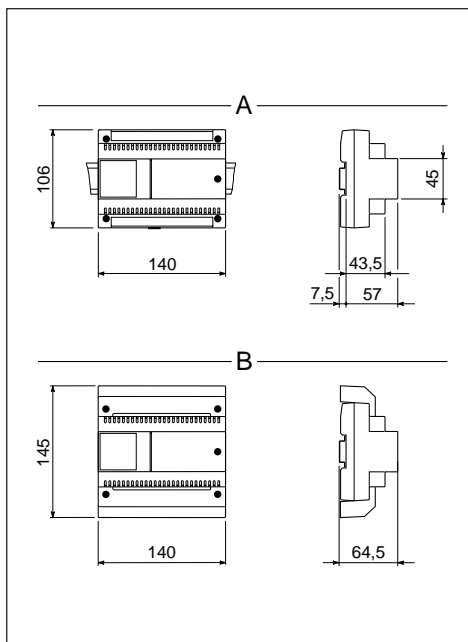

Fig. 1

COLLEGAMENTI

Per accedere alle morsettiere togliere i coprimorsetti. Si consiglia di utilizzare, per il collegamento dei telefoni, cavo telefonico da 6/10.

Distanza massima tra interfaccia telefonica e telefono: 100 m.

NOTA. L'apparechio va collegato solo su linee telefoniche analogiche non su linee digitali ISDN.

Funzione dei morsetti

Morsettiere T (linea telefonica)

- ae linea telefonica entrante
- be linea telefonica entrante
- au linea telefonica uscente
- bu linea telefonica uscente

Morsettiere IN

- B ingresso linea videocitofonica

Morsettiere A

- ~ } rete
- ~ }

NOTA. Quando é inserito (ON) il ponticello SW1 l'apparecchio disabilita la programmazione dal telefono.

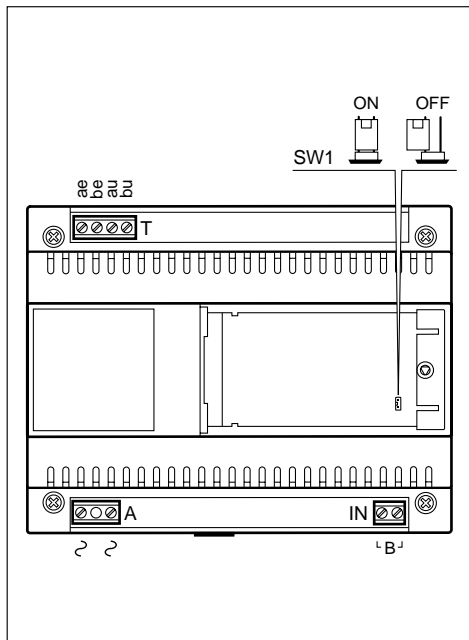

Fig. 2

PROGRAMMAZIONE

Configurazione di default

- Modalità riconoscimento flash: omologato.
- Codice di chiamata programmato per collegamento in impianti sistema 300: 65535.
- Intercettazione flash: disabilitata.

Ingresso e uscita dalle operazioni di programmazione

Per entrare in programmazione dal telefono collegato all'interfaccia telefonica:



Sollevare la cornetta
oppure



premere il tasto viva-voce.



Premere il pulsante commutazione citofono/telefono.



Digitare **9999**.

Durante questa fase si possono effettuare una o più programmazioni consecutive. L'inserimento dei codici di programmazione va eseguito durante la pausa del tono di programmazione.

Per uscire dalla fase di programmazione:



Sollevare la cornetta
oppure



premere il tasto viva-voce.

Dopo questa operazione si deve sentire un doppio tono di invito alla programmazione.



Digitare **9999**.

Al termine si sentirà il tono della linea urbana.

Programmazione codice di identificazione da telefono



Sollevare la cornetta
oppure



premere il tasto viva-voce.

Dopo questa operazione si deve sentire un doppio tono di invito alla programmazione.



Digitare **60**.



Digitare il codice utente (da 00000 ÷ 65535).

Al termine si deve sentire un triplo tono di conferma.



Riagganciare la cornetta
oppure



premere il tasto viva-voce.

PROGRAMMAZIONE

Programmazione codice di identificazione da alimentatore

Predisporre l'alimentatore XA/300LR in programmazione derivati interni, premendo il pulsante SERVICE per almeno 3 s.

Entrare in programmazione IT/300.

Premere il tasto autoinserimento o digitare R86.

Inviare il codice premendo il pulsante di chiamata, relativo all'apparecchio in programmazione, dal posto esterno.

Uscire dalla programmazione IT/300.

Ripetere la procedura per tutti i derivati da programmare.

Per terminare la programmazione di tutti gli apparecchi dell'impianto, premere brevemente il pulsante SERVICE dell'alimentatore XA/300LR.

Modalità riconoscimento flash



Sollevare la cornetta
oppure



premere il tasto viva-voce.

Dopo questa operazione si deve sentire un doppio tono di invito alla programmazione.



Digitare **20**.



Digitare **0** per riconoscimento flash omologato
oppure



1 per riconoscimento flash lungo.

Al termine si deve sentire un triplo tono di conferma.



Riagganciare la cornetta
oppure



premere il tasto viva-voce.

PROGRAMMAZIONE

Intercettazione flash



Sollevare la cornetta
oppure
premere il tasto viva-voce.



Dopo questa operazione si deve sentire un doppio tono di invito alla programmazione.



Digitare **63**.



Digitare **0** per intercettazione flash disabilitata (collegamento al telefono **bpt**)
oppure



1 per intercettazione flash abilitata (collegamento al telefono DTMF generico).

Al termine si deve sentire un triplo tono di conferma.



Riagganciare la cornetta
oppure



premere il tasto viva-voce.

Ripristino della configurazione di default



Sollevare la cornetta
oppure



premere il tasto viva-voce.

Dopo questa operazione si deve sentire un doppio tono di invito alla programmazione.



Digitare **00**.

Al termine si deve sentire un triplo tono di conferma.



Riagganciare la cornetta
oppure



premere il tasto viva-voce.

CARATTERISTICHE TECNICHE

- Alimentazione: 230Vca - 50 Hz.
- Assorbimento: 6VA max.
- Tensione di uscita: 24V.
- Tensione di chiamata 50V eff./50 Hz.
- Lunghezza max. dei cavi di connessione tra alimentatore, interfaccia e derivato: 250m (cavo telefonico da 6/10).
- Quantità di derivati sulla stessa linea: 5 max. (se ci sono dei derivati video utilizzare un distributore).
- Protezione elettronica ripristinabile.
- Deviazione di frequenza: secondo le norme CCITT.
- Abilitazione monitor per la durata della conversazione.
- Durata tempo di flash (R) programmabile.
- Collegamento linea urbana anche in mancanza di alimentazione.
- Temperatura di funzionamento: da 0 °C a +35 °C.
- Umidità relativa: 90% senza condensa.
- Classe d'isolamento II.
- Dimensioni: modulo da 8 unità basso per guida DIN.
- Frequenza toni di segnalazione: 375 Hz.

L'apparecchio è omologato secondo le norme CTR 21 e soddisfa la norma EN 60950 relativa alla sicurezza elettrica, e la direttiva 89/336/EEC modificata con 93/68/EEC, relative alla compatibilità elettromagnetica.

Approvazione europea rilasciata dal
BZT-ETS CERTIFICATION GmbH

CE 0681 X

TONI E RITMI

Toni di segnalazione

ITALIANO

FUNZIONE	TEMPO (secondi)							
	0	1	2	3	4	5	6	7
Programmazione	■ ■		■ ■		■ ■		■ ■	
Conferma di fine programmazione	■ ■ ■		■ ■ ■		■ ■ ■		■ ■ ■	
Attesa	■ ■				■ ■			
Avviso	■					■		

■ = Nota _ = Pausa

Ritmi di chiamata

FUNZIONE	TEMPO (secondi)							
	0	1	2	3	4	5	6	7
Urbana	■ ■ ■ ■						■ ■ ■ ■	
Citofonica da posto esterno	■ ■ ■ ■		■ ■				■ ■ ■ ■	
Citofonica da portiere	■ ■ ■ ■		■ ■	■ ■			■ ■ ■ ■	

■ = Nota _ = Pausa

GLOSSARIO

Citofono

Permette di comunicare con il posto esterno e di comandare l'apertura della porta.

Default

Con questo termine viene definita ogni predisposizione o programmazione eseguita dal fabbricante.

Flash (R)

Premendo questo tasto dal telefono collegato si predispongono l'interfaccia a ricevere un comando (e non un numero telefonico) dalla tastiera.

Linea urbana

Collegamento che permette di comunicare con gli utenti dell'elenco telefonico.

Posto esterno

Permette al visitatore di effettuare la chiamata all'utente e di conversare. Se è dotato di telecamera, trasmette le immagini al videocitofono in casa.

Telefono

Apparecchio che normalmente permette di fare e ricevere telefonate sulla linea urbana; con il centralino IT/200 il telefono può essere usato anche come citofono.

Telefono decadico

Telefono con disco combinatore; anche alcuni telefoni a tastiera sono decadici: il telefono è decadico se, componendo un numero, alla cornetta si odono degli scatti.

Telefono multifrequenza

Chiamato anche MF o DTMF, è il telefono più moderno.

Un telefono è multifrequenza se, componendo un numero, alla cornetta si odono dei toni.

Videocitofono

Oltre alle normali funzioni del citofono, permette di vedere sullo schermo il visitatore che chiama dal posto esterno.

FUNZIONI

Chiamata su linea urbana

È possibile inoltrare le chiamate nel modo abituale, come con ogni altro apparecchio.



Sollevare la cornetta
oppure



premere il tasto viva-voce.



Comporre sulla tastiera il numero desiderato.



A fine conversazione riagganciare la cornetta
oppure



premere il tasto viva-voce.

Risposta alle chiamate in arrivo



Sollevare la cornetta
oppure



premere il tasto viva-voce.



A fine conversazione riagganciare la cornetta
oppure



premere il tasto viva-voce.

Il telefono squilla con ritmi diversi a seconda che la chiamata provenga da una linea urbana o dal posto esterno.

Vedere il capitolo TONI E RITMI della suoneria.

Risposta a chiamata da posto esterno ed apertura della porta



Sollevare la cornetta
oppure



premere il tasto viva-voce.



Se si desidera far entrare il chiamante premere il tasto apriporta (per telefoni **bpt**, per altri telefoni consultare la tabella riassuntiva).



Riagganciare la cornetta
oppure



premere il tasto viva-voce.

NOTA. Se l'interfaccia è programmata con la funzione INTERCETTAZIONE FLASH disabilitata, non è possibile da un telefono standard multifrequenza, eseguire il comando quando si è in comunicazione con la linea urbana.

FUNZIONI

Autoinserimento su posto esterno

È possibile attivare il posto esterno per una qualsiasi delle seguenti esigenze (ad impianto libero):

- sorvegliare l'esterno con audio e video (se il posto esterno è dotato di telecamera);
- scambiare i posti esterni;
- attivare l'apriporta.
- attivare i comandi ausiliari.

Cambio interlocutore

Questo servizio consente all'utente, in comunicazione con una linea esterna o posto esterno, di rispondere ad una chiamata proveniente dall'altra linea mettendo in attesa la comunicazione in corso.

L'interlocutore non in conversazione viene informato di questa condizione mediante tono acustico.

NOTA. Durante la conversazione l'utente viene informato della chiamata in arrivo con avviso acustico.

Per cambiare interlocutore durante una conversazione:



Premere il tasto di commutazione citofono/telefono (per telefoni **bpt**, per altri telefoni consultare la tabella riassuntiva).

NOTA. Se l'interfaccia è programmata con la funzione **INTERCETTAZIONE FLASH** disabilitata, non è possibile da un telefono standard multifrequenza, eseguire il comando quando si è in comunicazione con la linea urbana.

Chiamata portiere



Sollevare la cornetta
oppure



premere il tasto viva-voce.

Attendere il tono di invito alla selezione.



Premere il tasto di chiamata portiere (per telefoni **bpt**, per altri telefoni consultare la tabella riassuntiva).



A fine conversazione riagganciare la cornetta

oppure



premere il tasto viva-voce.

NOTA. Se l'interfaccia è programmata con la funzione **INTERCETTAZIONE FLASH** disabilitata, non è possibile da un telefono standard multifrequenza, eseguire il comando quando si è in comunicazione con la linea urbana.

FUNZIONI

Comando ausiliario/luce scale da telefono



Solleverla la cornetta



oppure
premere il tasto viva-voce.

Attendere il tono di invito alla selezione.



Premere il tasto ausiliario (per telefoni **bpt**, per altri telefoni consultare la tabella riassuntiva).



Riagganciare la cornetta
oppure



premere il tasto viva-voce.

NOTA. Se l'interfaccia è programmata con la funzione INTERCETTAZIONE FLASH disabilitata, non è possibile da un telefono DTMF, eseguire il comando quando si è in comunicazione con la linea urbana.

AVVERTENZA. In impianti con segreto di conversazione questo comando è disponibile solo se il derivato interno è stato chiamato dal posto esterno.

Disabilitazione avviso acustico di chiamata in arrivo



Digitare **R83** prima di comporre il numero telefonico.

Per tutto il tempo della conversazione il tono di avviso viene disabilitato.





Utilizzare questa funzione quando viene effettuato il collegamento con un modem. Se si vuole ottenere in automatico la disabilitazione, aggiungere la serie di caratteri **I83**, (vedere le istruzioni del software della connessione telefonica).

Accesso ai servizi Telecom DTMF

L'accesso è possibile sempre quando si è configurata l'interfaccia come INTERCETTAZIONE FLASH disabilitata, mentre è possibile solo in comunicazione con la linea urbana e in assenza di chiamate dal posto esterno citofonico, quando è configurata come INTERCETTAZIONE FLASH abilitata.

FUNZIONI

Funzioni ottenibili con l'utilizzo del telefono **bpt**
e con telefoni standard

	TELEFONO BPT	TELEFONO MULTIFREQUENZA	TELEFONO DECADICO
PROGRAMMAZIONE	si	si	non possibile
CHIAMATA URBANA	diretto	diretto	diretto
RICEZIONE CHIAMATE URBANE/TELEFONICHE	si	si	si
ACCESSO AI SERVIZI TELECOM IN DTMF	si	si	non possibile
AUTOINSERIMENTO	 (monitor)	R+86	non possibile
APRIPORTA	 (key)	R+85	non possibile
AUSILIARIO/LUCE SCALE		R+88	non possibile
CHIAMATA PORTIERE		R+87	non possibile
CAMBIO INTERLOCUTORE		R+80	non possibile

CONTENTS

Instructions for the installer

Foreword	20
Warnings	21
Installation	22
Connections	23
Programming	24
- Default settings	24
- Entering and exiting the programming functions	24
- Programming the ID code via the telephone	24
- Programming the ID code via the power supplier	25
- Flash detection mode	25
- Flash interception	26
- Resetting default settings	26
Technical features	27
Tones and frequencies	28
- Signal tones	28
- Call frequencies	28

Instructions for the user

Glossary	29
Functions	30
- Call on local line	30
- Answering incoming calls	30
- Answering calls from entry panel and opening the door	30
- Self-connection on entry panel	31
- Interlocutor switching	31
- Porter call	31
- Telephone auxiliary/stair light control	32
- Disabling the incoming call warning tone	32
- Accessing Telecom DTMF services	32
- Functions available using the bpt telephone and standard telephone sets	33

FOREWORD

The telephone interface enables a telephone set to be connected to the series 300 video and audio control line.

In addition, apart from the **bpt** telephone, it enables ordinary decadic or DTMF sets, cordless phones, answering machines, modems, etc. to be used.

The unit also enables calls to be sent to an analogue or digital porter switchboard and to control the door lock release, centralized stair light functions, etc. For video entry systems, non-**bpt** telephone sets must be connected by means of a separator. The unit also enables calls to be sent to a porter switchboard and the door-lock release, centralized stair light controls etc. to be activated.

The unit is housed in a 8 DIN module.

Basic functions

- Direct access to the local telephone line.
- Connection to the series 300 video entry control system with self-connection function.
- Connection to the audio entry control system with conversation privacy.
- Telephone communication even during power outages.
- Different call tone for entry panel, porter switchboard and telephone calls.
- Hold (telephone/entry panel call).
- Telephone line protection.
- Programming of the unit using telephone set.
- Mains power supply.

WARNINGS

Read the warnings contained herein carefully as they provide important instructions for safe operation, installation and maintenance.

Having removed the packaging, make sure the unit is intact.

The packaging materials (plastic bags, foam polystyrene, etc.) must be kept out of the reach of children as they represent potential sources of danger.

The material must be disposed of according to the laws in force.

The installation of the system must comply with the safety rules in force.

Do not run telephone cables in the same raceways as electrical cables.

Install the unit in a fairly dust-free room, away from units liable to generate high-frequency electrical noise such as welding machines, electric motors, microwave ovens, air conditioners, etc.

It is advisable to install a suitable cutout and safety device upstream of the power supplier.

Before connecting up the unit, make sure the data on the rating plate correspond to the mains power supply.

This unit must be used only for the use for which it was explicitly designed; any other use shall be considered improper and hazardous.

The manufacturer cannot be held responsible for any damage as a result of improper, incorrect and unreasonable use.

Before cleaning or doing any maintenance work on the unit, disconnect it from the mains power supply by opening the system's switch.

In the event the unit is faulty and/or operates poorly, disconnect it from the power supply and do not tamper with it.

When in need of repair work, contact only technical servicing centres authorized by the manufacturer.

Failure to comply with the above provisions may compromise the safety of the unit.

The installer must make sure that the user information, where applicable, is to be found on the unit.

All the equipment making up the system must be used only for the user for which they were designed.

INSTALLATION

The unit, housed in a low profile module of 8 DIN units, can be installed without terminal covers in cabinets featuring DIN guides (EN 50022).

See fig. 1A for the overall dimensions.

Alternatively, it can be wall mounted, using the DIN guide supplied, and in this case will require terminal covers.

See fig. 1B for the overall dimensions.

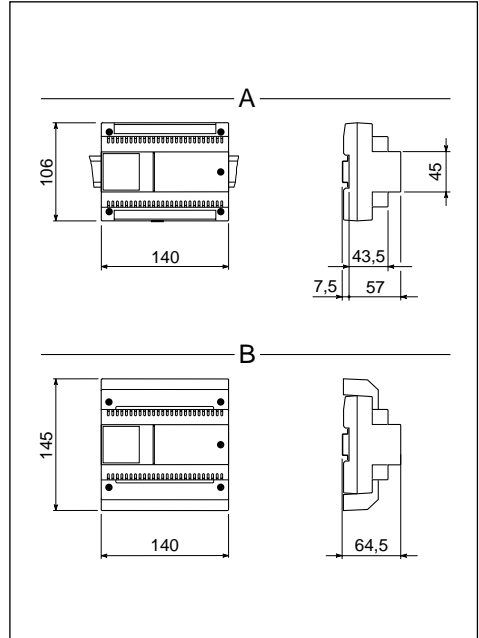

Fig. 1

CONNECTIONS

In order to access the terminals, remove the terminal covers. The use of a 6/10 telephone cable is recommended for connecting the telephones.

The maximum distance between the telephone interface and the telephone is 100 m.

NOTE. The unit must be connected on analogue telephone lines only and not digital ISDN lines.

Functions of each terminal

Terminal block T (telephone line)

- ae incoming telephone line
- be incoming telephone line
- au outgoing telephone line
- bu outgoing telephone line

Terminal block IN

- \overline{B} video entry control line input

Terminal block A

- ~ } mains

NOTE. When the jumper SW1 is ON, the unit disables programming via the telephone.

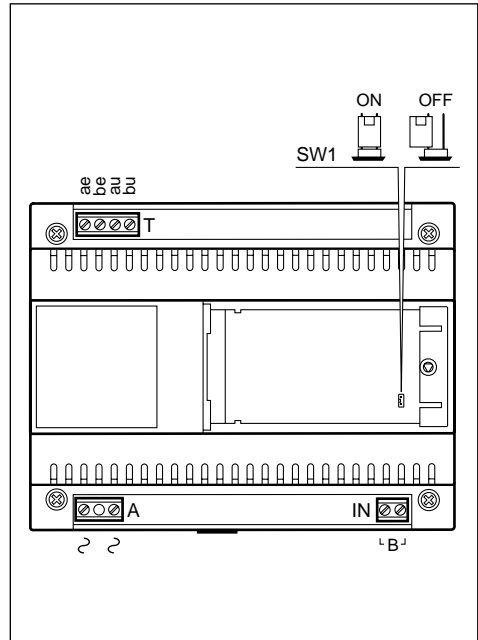

Fig. 2

PROGRAMMING

Default settings

- Flash detection mode: type approved.
- Programmed code for connection in systems 300: 65535.
- Flash interception: disabled.

Entering and exiting the programming functions

In order to enter programming mode via the telephone connected to the telephone interface:



Lift the receiver

or



press the hands-free key.



Press the entry hand-set/telephone transfer key.



Key in **9999**.

During this phase, one or more programming procedures can be carried out in a row. The programming codes must be entered during the pause in the programming tone.

In order to exit programming mode:



Lift the receiver

or



press the hands-free key.

Following this operation, a double tone should sound, prompting you to commence programming.



Key in **9999**.

Once finished, you should hear the local line dial tone.

Programming the ID code via the telephone



Lift the receiver

or



press the hands-free key.

Following this operation, a double tone should sound, prompting you to commence programming.



Key **60**.



Key in the user code (in the range 00000 to 65535).

Once finished, you should hear a triple tone confirming the setting.



Replace the receiver

or



press the hands-free key.

PROGRAMMING

Programming the ID code via the power supplier

Set the XA/300LR power supplier to **extension programming mode** by pressing the SERVICE key for at least 3 sec.

Enter the IT/300 programming mode.

Press the auto-connection key or key in R86.

Send the code by pressing the call button, relating to the unit being programmed, on the entry panel.

Exit the IT/300 programming mode.

Repeat the procedure for all the extensions to be programmed.

In order to finish the programming of all the units in the installation, press and release the SERVICE button on the XA/300LR power supplier.

Flash detection mode



Lift the receiver

or



press the hands-free key.

Following this operation, a double tone should sound, prompting you to commence programming.



Key in 20.



Press 0 for type approved flash detection

or



1 for long flash detection.

Once finished, you should hear a triple tone confirming the setting.



Replace the receiver

or



press the hands-free key.

PROGRAMMING

Flash interception



Lift the receiver

or



press the hands-free key.

Following this operation, a double tone should sound, prompting you to commence programming.



Key in **63**.



Press **0** to disable flash interception (connection to **bpt** telephone)

or



1 to enable flash interception (connection to generic DTMF telephone).

Once finished, you should hear a triple tone confirming the setting.



Replace the receiver

or



press the hands-free key.

Resetting default settings



Lift the receiver

or



press the hands-free key.

Following this operation, a double tone should sound, prompting you to commence programming.



Key in **00**.

Once finished, you should hear a triple tone confirming the setting.



Replace the receiver

or



press the hands-free key.

TECHNICAL FEATURES

- Supply voltage: 230V AC, 50 Hz.
- Current demand: 6VA max.
- Voltage output: 24V.
- Call voltage active 50V/50 Hz.
- Max. length of connecting cables for power supplier, interface and internal unit: 250 m (6/10 telephone cable).
- Amount of extensions on the same line: 5 max. (if there are any video unit, use a distributor)
- Reprimable electronic safety device.
- Frequency deviation: according to CCITT standards.
- Monitor enabling for the duration of the conversation.
- Programmable flash (R) length.
- Door lock release triggering time in the range 1 to 15 s.
- Local line connection even during power outages.
- Working temperature range: from 0 °C to +35 °C.
- Relative humidity: 90% with no condensation.
- Insulation rating: II.
- Dimensions: 8 DIN units, low profile module.
- Signal tone frequency: 375 Hz.

The unit is type approved according to standard CTR 21 and meets the requirements of the EN 60950 standard relating to electrical safety, and of the 89/336/EEC directive amended with 93/68/EEC directive relating to electromagnetic compatibility.

European approval issued by
BZT-ETS CERTIFICATION GmbH

CE 0681 X

TONES AND FREQUENCIES

Signal tones

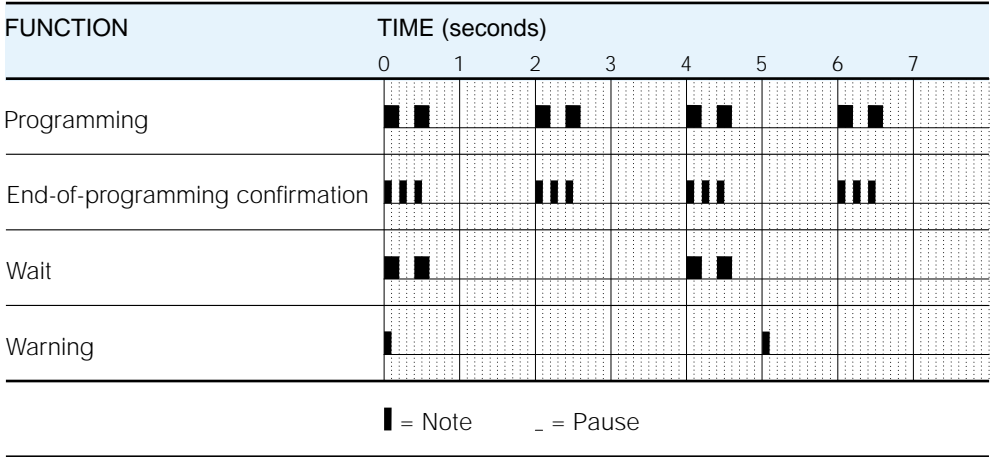

Call frequencies

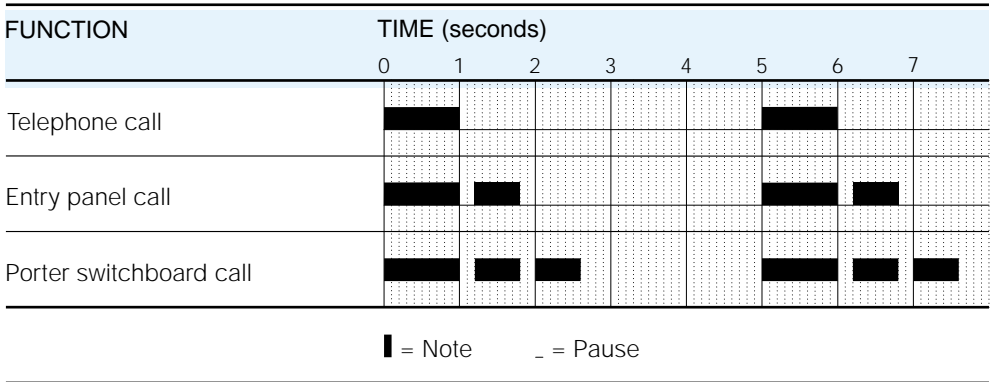

GLOSSARY

Handset

Enables the user to talk with the entry panel and release the door lock.

Default

This term is used to define any settings or programming performed by the manufacturer.

Flash (R)

When this button on the connected telephone is pressed, the interface stands by to receive a command (and not a telephone number) via the push-buttons.

Local line

Connection which enables communication with the other users on the telephone network.

Entry panel

Enables the visitor to call the occupant and talk with him/her.
Where it features a camera, the images are sent to the video entry handset in the home.

Telephone

Unit which normally enables telephone calls to be made and received on the local line; with the IT/200 switchboard, the telephone can also be used as an audio entry handset.

Decadic telephone

A telephone with a dial, through some push-button phones are also decadic: the telephone is decadic if you hear clicks in the receiver whilst the number is being dialled.

Multifrequency telephone

Also known as MF or DTMF, this is the more modern type of set.
A telephone is multifrequency if you hear tones in the receiver whilst the number is being dialled.

Video entry handset

Apart from the normal functions of the audio entry handset, this enables the visitor calling from the entry panel to be seen on the monitor.

FUNCTIONS

Call on local line

Calls can be made in the usual way, just as though you were using a normal telephone.



Lift the receiver
or



press the hands-free key.



Dial the desired number.



Replace the receiver
or



press the hands-free key.

Answering incoming calls



Lift the receiver
or



press the hands-free key.



Replace the receiver
or



press the hands-free key.

The telephone rings with different frequencies depending on whether the call is a telephone call or whether it is from the entry panel.

See section entitled TONES AND FREQUENCIES.

Answering calls from entry panel and opening the door



Lift the receiver
or



press the hands-free key.



If you want to let the caller in, press the door lock release button (in the case of **bpt** telephones; for other telephones, consult the summary table).



Replace the receiver
or



press the hands-free key.

***NOTE.** If the interface is programmed with the FLASH INTERCEPTION function disabled, the control will not work using a standard multifrequency set whilst communication of the local telephone line.*

FUNCTIONS

Self-connection on entry panel

The entry panel can be activated for any of the following needs (when the system is free):

- audio and video monitoring of the entrance (where the entry panel features a camera);
- exchanging entry panels;
- releasing door lock;
- releasing auxiliary command.

Interlocutor switching

This function enables the user, whilst communicating with an outside line or the entry panel, to answer a call on the other line, putting the current conversation on hold.

The interlocutor put on hold hears a tone advising him/her of the current hold status.

NOTE. During the conversation, a sound advise the user of the incoming call.

In order to switch between interlocutors during a conversation:



Press the entry handset/telephone transfer key (in the case of **bpt** telephones; for other telephones, consult the summary table).

NOTE. If the interface is programmed with the FLASH INTERCEPTION function disabled, the control will not work using a standard multifrequency set whilst communication of the local telephone line.

Porter call



Lift the receiver
or



press the hands-free key.

Wait for the dial tone.



Press the porter call key (in the case of **bpt** telephones; for other telephones, consult the summary table).



Replace the receiver
or



press the hands-free key.

NOTE. If the interface is programmed with the FLASH INTERCEPTION function disabled, the control will not work using a standard multifrequency set whilst communication of the local telephone line.

FUNCTIONS

Telephone auxiliary/stair light control



Lift the receiver
or



press the hands-free key.

Wait for the dial tone.



Press the auxiliary key (in the case of **bpt** telephones; for other telephones, consult the summary table).



Replace the receiver
or



press the hands-free key.

NOTE. *If the interface is programmed with the FLASH INTERCEPTION function disabled, the control will not work using a DTMF set whilst communicating of the local telephone line.*

WARNING. *In installations featuring conversation privacy, this control is only available if the extension has been called from the entry panel.*

Disabling the incoming call warning tone



Key in **R83** before dialling the telephone number.

The warning tone will remain disabled for the entire duration of the call.





Use this function when a modem connection is made. If you want the disabling to be automatic, add the series of digits **!83**, (see the software instructions for the telephone connection).

Accessing Telecom DTMF services

Access is always possible when the interface's FLASH INTERCEPTION is disabled, whilst it is only possible during communication with the local telephone line, with no incoming call from the entry panel, when the FLASH INTERCEPTION is enabled.

FUNCTIONS

Functions available using the **bpt** telephone and standard telephone sets

	BPT TELEPHONE	MULTIFREQUENCY TELEPHONE	DECADIC TELEPHONE
PROGRAMMING	yes	yes	not possible
LOCAL CALL	direct	direct	direct
RECEPTION LOCAL/TELEPHONE CALLS	yes	yes	yes
ACCESS TO DTMF SERVICES	yes	yes	not possible
SELF-CONNECTION	 (monitor)	R+86	not possible
DOOR LOCK RELEASE		R+85	not possible
AUXILIARY/STAIR LIGHT		R+88	not possible
PORTER CALL		R+87	not possible
INTERLOCUTOR SWITCHING		R+80	not possible

INHALTSVERZEICHNIS

Installationsanleitung

Allgemeines	.36
Anmerkungen	.37
Installation	.38
Anschlüsse	.39
Programmierung	.40
- Standardkonfiguration	.40
- Beginn und Ende der Programmiervorgänge	.40
- Programmierung des Erkennungscodes durch das Telefon	.40
- Programmierung des Erkennungscodes durch das Netzgerät	.41
- Flasherkennungsmodus	.41
- Flash-Auffangfunktion	.42
- Wiederherstellung der Standardkonfiguration	.42
Technische Daten	.43
Töne und Rhythmen	.44
- Signaltöne	.44
- Anrufrhythmen	.44

Bedienungsanleitung

Glossar	.45
Funktionen	.46
- Anruf auf Ortsleitung	.46
- Beantwortung der eingehenden Anrufe	.46
- Beantwortung des Anrufs von der Außenstation und Türöffner	.46
- Selbsteinschaltung auf der Außenstation	.47
- Wechsel des Gesprächsteilnehmers	.47
- Pfortneranruf	.47
- Steuerung der Zusatzfunktion/Treppenlicht vom Telefon aus	.48
- Ausschaltung der Tonmeldung des ankommenden Anrufs	.48
- Zugang zu den Telekom - Servicefunktionen DTMF	.48
- Durch das bpt Telefon und die Standardtelefone zugängliche Funktionen	.49

ALLGEMEINES

Die Telefonschnittstelle ermöglicht den Anschluß eines Telefonapparats an die Video- und Haussprechanlage der Serie 300. Über die Benutzung des **bpt**-Telefons hinaus können dank dieser Schnittstelle normale IWW- oder MFV-Telefon-apparate, Handys, Anrufbeantworter, Modems, usw., benutzt werden.

Über das Gerät können auch Anrufe an eine Pförtnerzentrale gesendet, der Türöffner und die zentralgesteuerten Treppenlichter, usw. betätigt werden.

Das Gehäuse hat die Abmessungen von 8 DIN-Einheiten.

Basisfunktionen

- Direktzugang zu der Amtsleitung.
- Anschluß an die Videosprechanlage der Serie 300 mit Selbsteinschaltfunktion.
- Anschluß an die Haussprechanlage mit Mithörsperre.
- Telefongespräch auch bei fehlender Stromversorgung.
- Rufunterscheidung der Außenstation, Pförtnerzentrale und Telefonleitung.
- Warteschleife (Ortsgespräch/Gespräch mittels Haussprechanlage).
- Schutzvorrichtung der Telefonleitung.
- Programmierung der Schnittstelle durch das Telefon.
- Versorgung aus dem Stromnetz.

ANMERKUNGEN

Die Anmerkungen der nachfolgenden Anleitung aufmerksam durchlesen, da sie wichtige Sicherheitshinweise über die Benutzung, Installation und Wartung liefern.

Verpackung abnehmen und sicherstellen, daß das Gerät einwandfrei ist.

Die Verpackungsteile (Plastikbeutel, Schaumpolystyrol, etc.) müssen außerhalb der Reichweite von Kindern aufbewahrt werden, da diese eine Gefahrenquelle darstellen können.

Die Verpackungsteile nicht in die Umwelt freisetzen, sondern sich an die geltenden Gesetze halten.

Der Anlagenbau muß den geltenden Sicherheitsvorschriften entsprechen.

Telefonkabel nicht zusammen mit elektrischen Kabeln legen.

Gerät nicht an einem staubigen Ort und fern von Geräten, die elektrische Hochfrequenzstörungen verursachen können, wie Schweißapparate, elektrische Motoren, Mikrowellenherd, Klimaanlage, etc. aufstellen.

Netzseitig ist ein Fehlerstromschalter einzusetzen.

Sich vor dem Anschluß des Apparats vergewissern, daß die Daten auf dem Schild denen des Versorgungsnetzes entsprechen.

Dieses Gerät ausschließlich für die eigens hierfür gedachte Benutzung gebrauchen; eine Zweckentfremdung ist unangebracht und somit gefährlich.

Der Hersteller übernimmt keine Haftung für eventuelle Schäden, die auf eine Zweckentfremdung, eine falsche oder unvernünftige Bedienung zurückzuführen sind. Vor jeglicher Reinigung oder Instandhaltung ist der Apparat durch die Öffnung des Anlagenschalters vom Stromnetz zu trennen.

Bei Defekten und/oder Störungen ist der Apparat von der Stromversorgung zu trennen; nicht umrüsten.

Im Falle einer Reparatur sich ausschließlich an eine vom Hersteller dazu ermächtigte Kundendienststelle wenden.

Die mangelnde Beachtung des oben Genannten kann die Sicherheit des Geräts beeinträchtigen.

Der Installateur muß sich vergewissern, daß die für den Benutzer erforderlichen Informationen auf der dafür vorgesehenen Stelle auf den Geräten vorhanden sind.

Alle Anlagengeräte dürfen ausschließlich für die hierfür gedachte Benutzung verwendet werden.

INSTALLATION

Der Apparat, der sich in einem Gehäuse zu 8 DIN-Einheiten, flach, befindet, kann in Kästen mit DIN-Schienen (EN 50022) ohne Klemmenabdeckungen eingebaut werden. Für die Außenabmessungen siehe Abb. 1A. Auch ist die Wandmontage, mit Klemmenabdeckungen und der Benutzung der mitgelieferten DIN-Schiene möglich. Für die Außenabmessungen siehe Abb. 1B.



Abb. 1

ANSCHLÜSSE

Klemmenabdeckungen abnehmen, um die Klemmleisten zu erreichen. Für den Telefonanschluß empfiehlt es sich, ein Telefonkabel mit einen Qüerschnitt von 0,6 mm zu verwenden.

Maximaler Abstand zwischen Telefonschnittstelle und Telefon: 100 m.

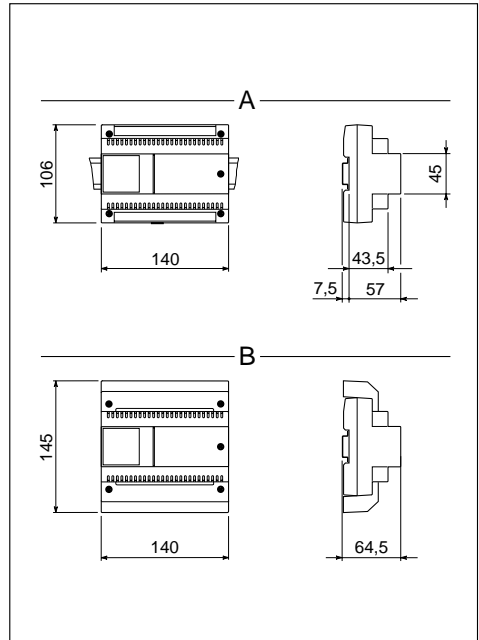
HINWEIS. Das Gerät darf nur an analogen und nicht an digitalen ISDN-Telefonleitungen angeschlossen werden.

Belegung der Klemmleisten

Klemmleiste T (Telefonleitung)

ae eingehende Telefonleitung

be eingehende Telefonleitung

au ausgehende Telefonleitung

bu ausgehende Telefonleitung

Klemmleiste IN

 B Eingang Videotürsprechanlage

Klemmleiste A

  Netz

ANMERKUNG. Bei eingeschalteter Überbrückungsklemme **SW1** (ON), schaltet das Gerät die Programmierung über das Telefon aus.



Abb. 2

PROGRAMMIERUNG

Standardkonfiguration

- Flasherkennungsmodus: freigegeben.
- Programmierter Code für einen Anschluß an Anlagen System 300: 65535.
- Flash-Auffangdienst: ausgeschaltet.

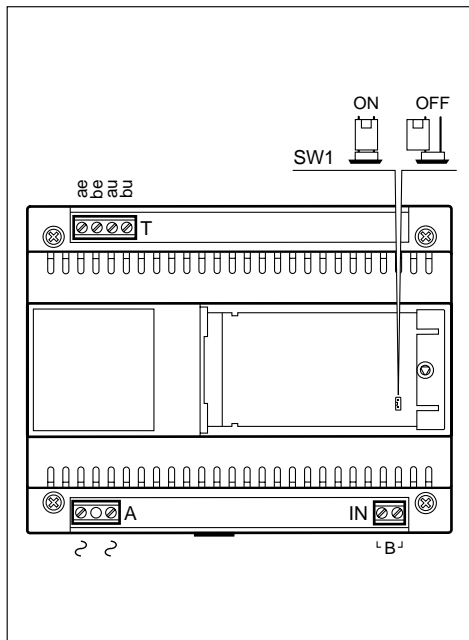
Beginn und Ende der Programmiervorgänge

Zur Programmierung durch das Telefon, das an die Telefonschnittstelle angeschlossen ist:



Hörer abnehmen



oder



Taste Freisprechfunktion drücken.



Umschalttaste Sprechgarantur/Telefon drücken.



9999 eingeben.

Während dieses Vorgangs können eine oder mehrere aufeinanderfolgende Programmierungen durchgeführt werden. Die Eingabe der Programmiercodes ist während der Pause des Programmiertons auszuführen.

Um die Programmierung zu beenden:



Hörer abnehmen



oder



Taste Freisprechfunktion drücken.

Nach diesem Vorgang muß ein doppelter Ton hörbar sein, der zum Programmierungsbeginn auffordert.



9999 eingeben.

Danach ist der Ton des Ortsnetzes hörbar.

Programmierung des Erkennungscode durch das Telefon



Hörer abnehmen

oder



Taste Freisprechfunktion drücken.

Nach diesem Vorgang muß ein doppelter Ton hörbar sein, der zum Programmierungsbeginn auffordert.



60 eingeben.



Bedienercode (von 0000 bis 65535).

Am Ende muß ein dreifacher Bestätigungston hörbar sein.



Hörer wieder auflegen

oder



Taste Freisprechfunktion drücken.

PROGRAMMIERUNG

Programmierung des Erkennungscode durch das Netzgerät

Drucktaste SERVICE mindestens 3 Sek. gedrückt halten, um das Netzgerät XA/300LR auf die Programmierung der Sprechgarnituren einzustellen.

Programmierung IT/300 beginnen.

Autoeinschaltungstaste drücken oder R86 eingeben.

Auf der Außenstation Ruftaste des zu programmierenden Geräts drücken und dabei Code senden.

Programmierung IT/300 beenden.

Vorgangsweise für alle zu programmierenden Sprechgarnituren wiederholen.

Um die Programmierung aller Anlagengeräte zu beenden, ist auf dem Netzgerät XA/300LR die Drucktaste SERVICE kurz zu drücken.

Flasherkennungsmodus



Hörer abnehmen
oder



Taste Freisprechfunktion drücken.

Nach diesem Vorgang muß ein doppelter Ton hörbar sein, der zum Programmierungsbeginn auffordert.

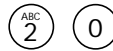

20 eingeben.



Für die freigegebene Flasherkennung 0 eingeben
oder



1 für die lange Flasherkennung.

Am Ende muß ein dreifacher Bestätigungston hörbar sein.



Hörer wieder auflegen
oder



Taste Freisprechfunktion drücken.

PROGRAMMIERUNG

Flash-Auffangfunktion



Hörer abnehmen

oder



Taste Freisprechfunktion drücken.

Nach diesem Vorgang muß ein doppelter Ton hörbar sein, der zum Programmierungsbeginn auffordert.

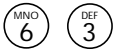

63 eingeben.



Für die ausgeschaltete Flashauffangfunktion (Anschluß an Telefon **bpt**) 0 eingeben

oder



1 für die eingeschaltete Flashauffangfunktion (Anschluß an allgemeines MFV-Telefon).

Am Ende muß ein dreifacher Bestätigungston hörbar sein.



Hörer wieder auflegen

oder



Taste Freisprechfunktion drücken.

Wiederherstellung der Standardkonfiguration



Hörer abnehmen

oder



Taste Freisprechfunktion drücken.

Nach diesem Vorgang muß ein doppelter Ton hörbar sein, der zum Programmierungsbeginn auffordert.



00 eingeben.

Am Ende muß ein dreifacher Bestätigungston hörbar sein.



Hörer wieder auflegen

oder



Taste Freisprechfunktion drücken.

TECHNISCHE DATEN

- Stromversorgung: 230V AC, 50 Hz.
- Stromaufnahme: 6VA max.
- Ausgangsspannung: 24V.
- Rufspannung 50V eff./50 Hz.
- Max. Länge der Anschlußkabel zwischen Netzgerät, Schnittstelle und Sprechstelle: 250 m (Telefonkabel mit einem Querschnitt von 0,6 mm).
- Anzahl der Sprechgarnituren auf derselben Leitung: 5 max. (bei Videosprechstellen ist ein Verteiler zu benutzen).
- Wiederherstellbare elektronische Schutzvorrichtung.
- Frequenzhub gemäß CCITT-Normen.
- Monitoreinschaltung für die gesamte Gesprächsdauer.
- Regelbare Flashdauer (R).
- Dauer der Auslösung des Türöffners von 1 bis 15 s.
- Anschluß an die Amtsleitung auch bei fehlender Stromversorgung.
- Betriebstemperatur: von 0 °C bis +35 °C.
- Relative Luftfeuchtigkeit: 90% ohne Kondenswasser.
- Schutzklasse II.
- Abmessungen: 8 DIN-Einheiten, flach.
- Frequenz der Signaltöne: 375 Hz.

Das Gerät wurde gemäß den Vorschriften CTR 21 zugelassen und erfüllt die Vorschrift EN 60950 über die elektrische Sicherheit und die europäische Richtlinie 89/336/EEC, durch 93/68/EEC abgeändert, über die elektromagnetische Kompatibilität.

Die europäische Genehmigung wurde von BZT-ETS CERTIFICATION GmbH erlassen

CE 0681 X

TÖNE UND RHYTHMEN

Signaltöne

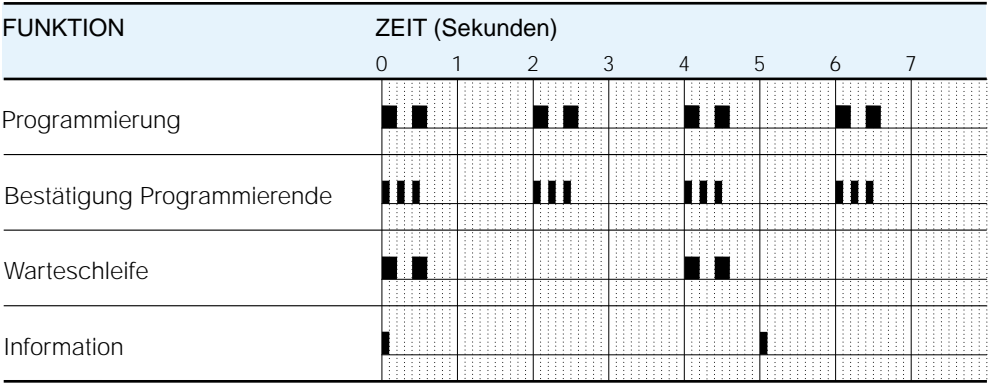

█ = Note _ = Pause

DEUTSCH

Anrufrhythmen

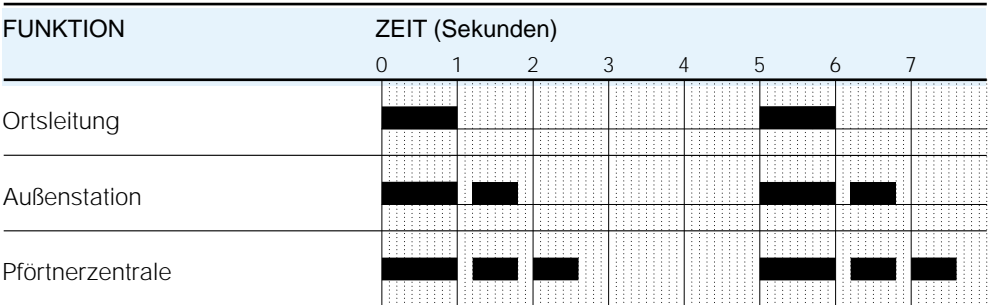

█ = Note _ = Pause

GLOSSAR

Sprechgarnitur

Ermöglicht die Verbindungsaufnahme zu der Außenstation und die Steuerung des Türöffners.

Standard

Dieser Begriff definiert jegliche, vom Hersteller durchgeführte Voreinstellung oder Programmierung.

Flash (R)

Durch diesen Tastendruck auf dem Telefon wird die Schnittstelle auf den Empfang einer Steuerfunktion vorbereitet.

Amtsleitung

Verbindung, die ein Gespräch zwischen zwei Teilnehmer am öffentlicher Netz herstellt.

Außenstation

Gibt dem Besucher die Möglichkeit, den Teilnehmer anzurufen und mit diesem ein Gespräch zu führen.

Falls mit Videokamera ausgestattet, werden die Bilder der Videosprechanlage ins Haus gesendet.

Telefon

Ein Apparat, durch den man normalerweise Telefonanrufe auf der Amtsleitung empfängt und vornimmt; mit der Zentrale IT/200 kann es auch als Sprechgarnitur verwendet werden.

IWV-Telefon

Telefon mit Wählscheibe oder auch mit Nummerntastatur. Die IWV-Wahl erkennt man daran, daß beim Anwählen einer Rufnummer in Hörer die Impulse herauszuhören sind.

MFV-Telefon

Es handelt sich um ein Mehrfrequenztelefon, wenn beim Anwählen einer Rufnummer im Hörer einzelne Töne unterschiedlicher Frequenz zu hören sind.

Videosprechgarnitur

Über die normalen Funktionen der Sprechgarnitur hinaus zeigt es auf dem Bildschirm den Besucher, der von der Außenstation anruft.

FUNKTIONEN

Anruf auf Amtsleitung

Die Anrufe können wie gewohnt, wie mit jeglichem anderen Apparat, vorgenommen werden.



Hörer abnehmen



oder



Taste Freisprechfunktion drücken.



Die gewünschte Rufnummer in die Tastatur eingeben.



Bei Gesprächsende Hörer wieder auflegen



Taste Freisprechfunktion drücken.

Beantwortung der eingehenden Anrufe



Hörer abnehmen



oder



Taste Freisprechfunktion drücken.



Bei Gesprächsende Hörer wieder auflegen



Taste Freisprechfunktion drücken.

Das Telefon läutet mit unterschiedlichen Rhythmen, je nachdem, ob der Anruf von einer Ortsleitung oder von der Außenstation kommt.

Siehe Kapitel Klingel- TÖNE UND RHYTHMEN.

Beantwortung des Anrufs von der Außenstation und Türöffner



Hörer abnehmen



oder



Taste Freisprechfunktion drücken.



Falls die anrufende Person eintreten soll, Taste Türöffner (für **bpt**-Telefone, für andere Telefone siehe zusammenfassende Tabelle) drücken.



Hörer wieder auflegen



oder

Taste Freisprechfunktion drücken.

ANMERKUNG. Wenn die Schnittstelle auf ausgeschaltete FLASHAUFFANGFUNKTION programmiert ist, kann von einem Mehrfrequenz-Standardtelefon und bei bestehender Verbindung mit der Ortsleitung, keine Steuerfunktion ausgesendet werden.

FUNKTIONEN

Selbsteinschaltung auf der Außenstation

Die Einschaltung der Außenstation ist infolge einer der folgenden Erfordernisse möglich (bei freier Anlage):

- die Audio- und Videoüberwachung der Umgebung (falls die Außenstation über eine Videokamera verfügt);
- die Umschaltung zwischen den Außenstationen;
- die Betätigung des Türöffners.
- Zusatzsteuerfunktionen betätigen.

Wechsel des Gesprächsteilnehmers

Durch diese Dienstsfunction kann der Bediener, der mit einer externen Leitung oder der Außenstation verbunden ist, auf einen Anruf auf einer anderen Leitung antworten, indem die bestehende Verbindung geparkt wird.

Ein akustischer Ton meldet dem geparkten Gesprächsteilnehmer diesen Zustand.

ANMERKUNG. Während des Gesprächs meldet ein akustischer Hinweis dem Bediener den eingehenden zweiten Anruf.

Um während des Gesprächs auf einen anderen Teilnehmer umzuschalten:



Umschalttaste Sprechgarnitur/ Telefon drücken (für **bpt**-Telefone, für andere Telefone siehe zusammenfassende Tabelle).

ANMERKUNG. Wenn die Schnittstelle auf ausgeschaltete **FLASHAUFFANGFUNKTION** programmiert ist, kann von einem Mehrfrequenz-Standardtelefon und bei bestehender Verbindung mit der Ortsleitung, keine Steuerfunktion ausgesendet werden.

Pförtneranruf



Hörer abnehmen
oder



Taste Freisprechfunktion drücken.

Ton abwarten, der zum Anwählen auffordert.



Taste Pförtneranruf drücken (für **bpt**-Telefone, für andere Telefone siehe zusammenfassende Tabelle).



Bei Gesprächsende Hörer wieder auflegen
oder



Taste Freisprechfunktion drücken.

ANMERKUNG. Wenn die Schnittstelle auf ausgeschaltete **FLASHAUFFANGFUNKTION** programmiert ist, kann von einem Mehrfrequenz-Standardtelefon und bei bestehender Verbindung mit der Ortsleitung, keine Steuerfunktion ausgesendet werden.

FUNKTIONEN

Steuerung der Zusatzfunktion/Treppenlicht vom Telefon aus



Hörer abnehmen

oder



Taste Freisprechfunktion drücken.

Ton abwarten, der zum Anwählen auffordert.



Zusatztaste drücken (für **bpt**-Telefone, für andere Telefone siehe zusammenfassende Tabelle).



Hörer wieder auflegen

oder



Taste Freisprechfunktion drücken.

***ANMERKUNG.** Wenn die Schnittstelle auf ausgeschaltete FLASHAUFFANGFUNKTION programmiert ist, kann von einem DTMF-Telefon und bei bestehender Verbindung mit der Ortsleitung, keine Steuerfunktion ausgesendet werden.*

Ausschaltung der Tonmeldung des ankommenden Anrufs



R83 eingeben und dann die Telefonnummer wählen.

Während des ganzen Telefonanrufs bleibt das Meldezeichen ausgeschaltet.





Diese Funktion nur bei einem Modem-Anschluß benutzen. Falls die Ausschaltung automatisch erfolgen soll, ist die Zeichenfolge **!83**, (siehe Anweisungen Telefonanschluß-Software) hinzuzufügen.

Zugang zu den Telekom-Servicefunktionen DTMF

Der Zugang ist immer dann möglich, wenn die Schnittstelle als ausgeschaltete FLASH-SCHNITTSTELLE konfiguriert wurde; bei eingeschalteter FLASH-SCHNITTSTELLE nur dann, wenn eine Verbindung mit der Amtsleitung besteht und von der Außenstation der Haussprechanlage keine Anrufe erfolgen.

FUNKTIONEN

Durch das **bpt** Telefon und die Standardtelefone zugängliche Funktionen

	BPT-TELEFON	MULTIFREQUENZ TELEFON	IWV-TELEFON
PROGRAMMIERUNG	ja	ja	nicht möglich
ORTSGESPREÄCH	direkt	direkt	direkt
EMPFANG VON ORTSGESPREÄCHEN/TELEFONANRUFEN	ja	ja	ja
ZUGANG ZU DEN DTMF-TELEKOM SERVICEFUNKTIONEN	ja	ja	nicht möglich
SELBSTEINSCHALTUNG	 (monitor)	R+86	nicht möglich
TÜRÖFFNER		R+85	nicht möglich
ZUSATZFUNKTION/TREPPENLICHTER		R+88	nicht möglich
PFÖRTNERANRUF		R+87	nicht möglich
WECHSEL DES GESPRÄCHSTEILNEHMES		R+80	nicht möglich

SOMMAIRE

Instructions pour l'installateur

Généralités	52
Conseils	53
Installation	54
Connexions	55
Programmation	56
- Configuration de default	56
- Entrée et sortie des opérations de programmation	56
- Programmation code d'identification depuis téléphone	56
- Programmation code d'identification depuis alimentation	57
- Mode reconnaissance flash	57
- Interception flash	58
- Rétablissement de la configuration de default	58
Caractéristiques techniques	59
Tonalités et rythmes	60
- Tonalités de signalisation	60
- Rythmes d'appel	60

Instructions pour l'utilisateur

Glossaire	61
Fonctions	62
- Appel sur ligne urbaine	62
- Réponse aux appels en arrivée	62
- Réponse à un appel depuis poste extérieur et ouverture de la porte	62
- Autointroduction sur poste extérieur	63
- Changement d'interlocuteur	63
- Appel concierge	63
- Commande auxiliaire/minuterie avec téléphone	64
- Exclusion signal acoustique avertissant d'un appel en arrivée	64
- Accès aux services Telecom DTMF	64
- Fonctions possibles avec l'utilisation du téléphone bpt et avec des téléphones standard	65

GENERALITES

L'interface téléphonique permet de relier un appareil téléphonique à la ligne portier vidéo et portier électronique série 300.

Outre le téléphone **bpt**, elle permet également d'utiliser des appareils de téléphone normaux à décades ou DTMF, des téléphones sans fil, un répondeur téléphonique, un modem, etc. Dans des installations portier vidéo, les téléphones qui ne sont pas **bpt** doivent être branchés avec un filtre séparateur.

L'appareil sert également à envoyer des appels à une centrale de conciergerie et de commander les fonctions ouvre-porte, minuterie centralisée, etc.

L'appareil est réalisé dans un boîtier DIN à 8 modules.

Fonction de base

- Accès direct à la ligne urbaine.
- Connexion au système portier vidéo série 300 avec fonction d'autointroduction.
- Connexion au système portier électronique avec secret de conversation.
- Communication téléphonique même en absence d'alimentation secteur.
- Appel diversifié depuis poste extérieur, centrale de conciergerie et ligne téléphonique.
- Mise en attente communication (urbaine/portier électronique).
- Protection ligne téléphonique.
- Programmation de l'appareil au moyen du téléphone.
- Alimentation par le secteur.

CONSEILS

Lire attentivement les instructions contenues dans le présent livret car elles fournissent d'importantes indications concernant la sécurité d'emploi, d'installation et d'entretien.

Après avoir sorti l'appareil de son emballage, contrôler s'il est en bon état.

Les éléments de l'emballage (sachets en plastique, polystyrène expansé, etc.) ne doivent pas être laissés à la portée des enfants car ils pourraient être dangereux.

L'élimination de l'emballage doit être fait conformément aux normes en vigueur.

L'exécution de l'installation doit répondre aux normes de sécurité en vigueur.

Ne pas faire passer au même endroit les câbles du téléphone et les câbles électriques.

Installer l'appareil dans un local non poussiéreux, loin de tous appareils pouvant créer des dérangements électriques de haute fréquence comme par ex.: soudeuses, moteurs électriques, fours à micro-ondes, climatiseurs, etc.

Il est opportun de prévoir en amont de l'alimentation un interrupteur de coupure et de protection adéquat.

Avant de connecter l'appareil, s'assurer

que les données de la plaque signalétique correspond à celle du réseau de distribution.

Cet appareil ne devra être destiné qu'à l'emploi pour lequel il a été expressément conçu. Toute autre utilisation sera considérée comme impropre et dangereuse.

Le constructeur ne sera pas tenu responsable de tous dommages dérivant d'une utilisation inappropriée, erronée et irraisonnée. Avant d'effectuer toute opération de nettoyage ou d'entretien, couper le courant du réseau d'alimentation en ouvrant l'interrupteur de l'installation.

En cas de panne et/ou de défaillance de fonctionnement, couper le courant et ne pas manipuler l'appareil.

Pour toute réparation, s'adresser uniquement à un centre de service après-vente agréé.

Le non-respect des indications ci-dessus peut compromettre la sécurité de l'appareil. L'installateur doit s'assurer que les informations pour l'utilisateur, quand elles sont prévues, soient présentes sur l'appareil.

Tous les appareils constituant l'installation devront être destinés exclusivement à l'emploi pour lequel ils ont été conçus.

INSTALLATION

L'appareil réalisé dans un boîtier à 8 unités bas, peut être installé sans couvre-bornes dans des boîtiers munis de rail DIN (EN 50022). Pour les dimensions d'encombrement, voir la fig. 1A.

Ou bien il peut être installé au mur, avec couvre-bornes, en utilisant le rail DIN fourni en standard. Pour les dimensions d'encombrement, voir la fig. 1B.

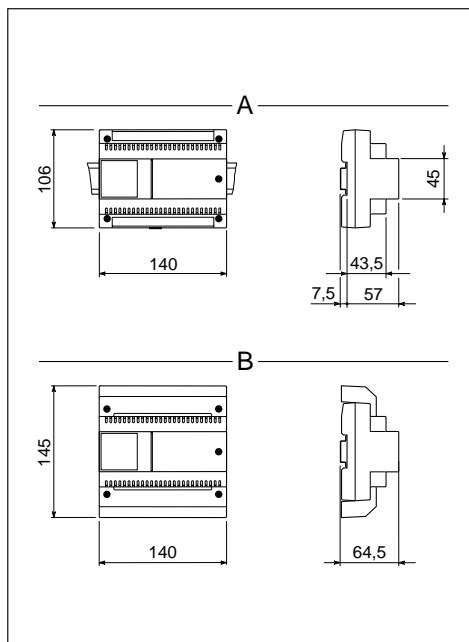

Fig. 1

CONNEXIONS

Pour accéder aux borniers, enlever les couvre-bornes. Pour la connexion des téléphones, il est conseillé d'utiliser le câble de 6/10.

Distance maximale entre interface téléphonique et téléphone: 100 m.

NOTA. L'appareil ne doit être raccordé que sur des lignes téléphoniques analogiques et non pas sur des lignes digitales ISDN.

Fonction des bornes

Bornier T (ligne téléphonique)

- ae ligne téléphonique entrante
- be ligne téléphonique entrante
- au ligne téléphonique sortante
- bu ligne téléphonique sortante

Bornier IN

- B entrée ligne portier vidéo

Bornier A

- ~ } secteur

NOTE. Quand le cavalier **SW1** est enclenché (ON), l'appareil exclut la programmation depuis le téléphone.

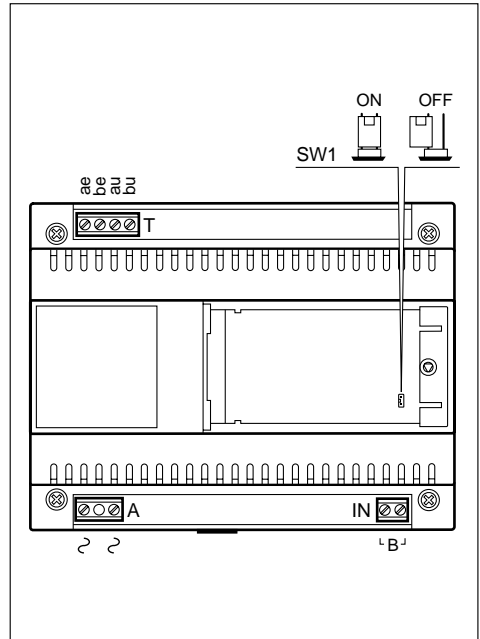

Fig. 2

PROGRAMMATION

Configuration de default

- Mode reconnaissance flash: homologué.
- Code programmé pour connexion dans des installations système 300: 65535.
- Interception flash: exclu.

Entrée et sortie des opérations de programmation

Pour entrer en mode programmation avec le téléphone relié à l'interface téléphonique:



Soulever le récepteur
ou bien



appuyer sur la touche vive-voix.



Appuyer sur la touche de commutation combiné/téléphone.



Taper 9999.

Pendant cette phase, il est possible d'effectuer une ou plusieurs programmations consécutives.

L'entrée des codes de programmation doit être effectuée pendant la pause de la tonalité de programmation.

Pour sortir de la phase de programmation:



Soulever le récepteur
ou bien



appuyer sur la touche vive-voix.

Après cette opération, on doit entendre une double tonalité invitant à la programmation.



Taper 9999.

Après cette opération, on entendra la tonalité de la ligne urbaine.

Programmation code d'identification depuis le téléphone



Soulever le récepteur
ou bien



appuyer sur la touche vive-voix.

Après cette opération, on doit entendre une double tonalité invitant à la programmation.



Taper 60.



Taper le code utilisateur (de 00000 à 65535).

Après cette opération, on doit entendre une triple tonalité de confirmation.



Raccrocher
ou bien



appuyer sur la touche vive-voix.

PROGRAMMATION

Programmation code d'identification depuis l'alimentation

Mettre l'alimentation XA/300LR en mode programmation postes intérieurs en appuyant sur la touche SERVICE pendant au moins 3 s.

Entrer en mode programmation IT/300.

Appuyer sur la touche auto-branchement ou taper R86.

Envoyer le code en appuyant sur le bouton d'appel, relatif à l'appareil à programmer, sur le poste extérieur.

Sortir de la programmation IT/300.

Répéter ces opérations pour tous les postes intérieurs à programmer.

Pour terminer la programmation de tous les appareils de l'installation, presser légèrement le bouton SERVICE de l'alimentation.

Mode reconnaissance flash



Soulever le récepteur
ou bien



appuyer sur la touche vive-voix.

Après cette opération, on doit entendre une double tonalité invitant à la programmation.



Taper **20**.



Taper **0** pour reconnaissance flash homologué

ou bien



1 pour reconnaissance flash long.

Après cette opération, on doit entendre une triple tonalité de confirmation.



Raccrocher
ou bien



appuyer sur la touche vive-voix.

PROGRAMMATION

Interception flash



Soulever le récepteur
ou bien



appuyer sur la touche vive-voix.

Après cette opération, on doit entendre une double tonalité invitant à la programmation.



Taper **63**.



Taper **0** pour interception flash exclu (connexion au téléphone **bpt**)
ou bien



1 pour interception flash activée (connexion au téléphone DTMF générique)

Après cette opération, on doit entendre une triple tonalité de confirmation.



Raccrocher
ou bien



appuyer sur la touche vive-voix.

Rétablissement de la configuration de default



Soulever le récepteur
ou bien



appuyer sur la touche vive-voix.

Après cette opération, on doit entendre une double tonalité invitant à la programmation.



Taper **00**.

Après cette opération, on doit entendre une triple tonalité de confirmation.



Raccrocher
ou bien



appuyer sur la touche vive-voix.

CARACTERISTIQUES TECHNIQUES

- Alimentation: 230Vca, 50 Hz.
- Consommation: 6VA maxi.
- Tension de sortie: 24V.
- Tension d'appel: 50V eff./50 Hz.
- Long. maxi des câbles de connexion entre alimentation, interface et poste intérieur: 250 m (câble téléphonique de 6/10).
- Nombre de postes intérieurs sur la même ligne: 5 maxi (s'il y a des postes intérieurs vidéo, utiliser un distributeur).
- Possibilité de rétablir la protection électronique.
- Déviation de fréquence: suivant les normes CCITT.
- Mise en service moniteur pour la durée de la conversation.
- Durée temps flash (R) programmable.
- Connexion ligne urbaine même en absence d'alimentation secteur.
- Température de fonctionnement: de 0 °C à +35 °C.
- Humidité relative: 90% sans condensation.
- Classe d'isolation II.
- Dimensions: module de 8 unités bas pour rail DIN.
- Fréquence tonalités de signalisation: 375 Hz.

L'appareil est homologué suivant les normes CTR 21 et satisfait à la norme EN 60950 relative à la sécurité électrique et à la directive 89/336/EEC modifiée par la directive 93/68/EEC relative à la compatibilité électromagnétique.

Approbation européenne délivrée par le
BZT-ETS CERTIFICATION GmbH

CE 0681 X

TONALITES ET RYTHMES

Tonalités de signalisation

FONCTION	TEMPS (secondes)							
	0	1	2	3	4	5	6	7
Programmation	■ ■		■ ■		■ ■		■ ■	
Confirmation de fin de programmation	■ ■ ■		■ ■ ■		■ ■ ■		■ ■ ■	
Attente	■ ■				■ ■			
AVIS	■					■		

■ = Note _ = Pause

Rythmes d'appel

FONCTION	TEMPS (secondes)							
	0	1	2	3	4	5	6	7
Urbaine	■ ■ ■ ■					■ ■ ■ ■		
Poste extérieur	■ ■ ■ ■	■ ■				■ ■ ■ ■	■ ■	
Centrale de conciergerie	■ ■ ■ ■	■ ■	■ ■			■ ■ ■ ■	■ ■	■ ■

■ = Note _ = Pause

GLOSSAIRE

Combiné

Il permet de communiquer avec le poste extérieur et de commander l'ouverture de la porte.

Default

On entend avec ce terme toute opération prévue sur l'appareil ou programmation effectuée en usine par le fabricant.

Flash (R)

En appuyant sur cette touche sur le téléphone relié, l'interface est prête à recevoir une commande (et non un numéro de téléphone) effectuée avec le clavier.

Ligne urbaine

Connexion qui permet de communiquer avec les abonnés de l'annuaire téléphonique.

Poste extérieur

Il permet au visiteur d'appeler la personne intéressée et de converser.

S'il est doté de caméra, il transmet les images sur le moniteur installée dans la maison.

Téléphone

Appareil qui normalement permet de téléphoner ou de recevoir une communication téléphonique sur la ligne urbaine. Avec la centrale IT/200, le téléphone peut également être utilisé comme combiné.

Téléphone à décades

Téléphone à cadran: certains téléphones à touches sont également à décades: un téléphone est à décades si, lorsque l'on compose un numéro, on entend dans le récepteur les unités.

Téléphone multifréquence

Il est également appelé MF ou DTMF, c'est le téléphone le plus moderne.

Un téléphone est multifréquence si lorsque l'on compose un numéro, on entend dans le récepteur des tonalités.

Portier vidéo

Outre les fonctions du combiné, il permet de voir sur un écran le visiteur qui appelle depuis le poste extérieur.

FONCTIONS

Appel sur ligne urbaine

Il est possible d'appeler comme avec les autres appareils.



Soulever le récepteur
ou bien



appuyer sur la touche vive-voix.



Composer sur le clavier le numéro désiré.



En fin de conversation, raccrocher
ou bien



appuyer sur la touche vive-voix.

Réponse aux appels en arrivée



Soulever le récepteur
ou bien



appuyer sur la touche vive-voix.



En fin de conversation, raccrocher
ou bien



appuyer sur la touche vive-voix.

Le téléphone sonne avec des rythmes différents suivant que l'appel provienne d'une ligne urbaine ou bien du poste extérieur. Voir le chapitre TONALITES ET RYTHMES de la sonnerie.

Réponse à un appel

provenant du poste extérieur et ouverture de la porte



Soulever le récepteur
ou bien



appuyer sur la touche vive-voix.



Si vous désirez faire entrer le visiteur, appuyer sur la touche ouvre-porte (pour les téléphones **bpt**. Pour d'autres téléphones, consulter le tableau récapitulatif).



Raccrocher
ou bien



appuyer sur la touche vive-voix.

NOTE. Si l'interface est programmée avec la fonction INTERCEPTION FLASH exclue, avec un téléphone standard multifréquence, il n'est pas possible d'effectuer cette commande si l'on est en communication avec la ligne urbaine.

Autointroduction

FONCTIONS

sur le poste extérieur

Il est possible d'activer le poste extérieur pour l'un des besoins suivants (ad impianto libero):

- surveiller l'extérieur avec portier audio et vidéo (si le poste extérieur est doté de caméra);
- échanger les postes extérieurs;
- enclencher l'ouvre-porte.
- enclencher les commandes auxiliaires.

Changement d'interlocuteur

Ce service permet à l'utilisateur en communication avec une ligne extérieure ou un poste extérieur de répondre à un appel provenant de l'autre ligne en mettant en attente la communication en cours.

L'interlocuteur qui ne converse pas est informé de cette condition moyennant une tonalité acoustique.

NOTE. Pendant la conversation, l'utilisateur est informé de l'appel en arrivée avec un avis acoustique.

Pour changer d'interlocuteur pendant une conversation:



Appuyer sur la touche de commutation combiné/téléphone (pour les téléphones **bpt**. Pour les autres types de téléphones, consulter le tableau récapitulatif).

NOTE. Si l'interface est programmée avec la fonction INTERCEPTION FLASH exclue, avec un téléphone standard multifréquence, il n'est pas possible d'effectuer cette commande si l'on est en communication avec la ligne urbaine.

Appel concierge



Soulever le récepteur
ou bien



appuyer sur la touche vive-voix.

Attendre la tonalité invitant à la sélection.



Appuyer sur la touche appel concierge (pour les téléphones **bpt**. Pour les autres téléphones, consulter le tableau récapitulatif).



En fin de conversation, raccrocher
ou bien



appuyer sur la touche vive-voix.

NOTE. Si l'interface est programmée avec la fonction INTERCEPTION FLASH exclue, avec un téléphone standard multifréquence, il n'est pas possible d'effectuer cette commande si l'on est en communication avec la ligne urbaine.

Commande auxiliaire/minuterie

FONCTIONS

avec téléphone



Soulever le récepteur
ou bien



appuyer sur la touche vive-voix.

Attendre la tonalité invitant à la sélection.



Appuyer sur la touche auxiliaire
(pour les téléphones **bpt**. Pour
les autres téléphones, consulter
le tableau récapitulatif).



Raccrocher
ou bien



appuyer sur la touche vive-voix.

NOTE. Si l'interface est programmée avec la fonction INTERCEPTION FLASH exclue, avec un téléphone DTMF, il n'est pas possible d'effectuer cette commande si l'on est en communication avec la ligne urbaine.

Exclusion signal acoustique

avertissant d'un appel en arrivée



Taper **R83** avant de composer le numéro de téléphone.

Pendant tout le temps de la conversation, le ton du signal acoustique est exclus.





Utiliser cette fonction pour effectuer un raccordement à un modem. Si l'on désire obtenir l'exclusion en automatique, ajouter la série de caractères **!83**, (voir la notice du logiciel de la connexion téléphonique).

Accès aux services Telecom DTMF

L'accès est toujours possible lorsque l'on a configuré l'interface avec INTERCEPTION FLASH exclue. Lorsqu'elle est configurée avec INTERCEPTION FLASH enclenchée, l'accès est possible uniquement en communication avec la ligne urbaine et en absence d'appels depuis le poste extérieur du portier électronique.

FONCTIONS

Fonctions possibles avec l'utilisation du téléphone **bpt** et avec des téléphones standard

	TELEPHONE BPT	TELEPHONE MULTIFREQUENCE	TELEPHONE A DECADES
PROGRAMMATION	oui	oui	impossible
APPEL URBAIN	direct	direct	direct
RECEPTION APPELS URBAINS/TELEPHONIQUES	oui	oui	oui
ACCESS AUX SERVICES TELECOM EN DTMF	oui	oui	impossible
AUTOINTRODUCTION	 (monitor)	R+86	impossible
OUVRE-PORTE		R+85	impossible
AUXILIAIRE/MINUTERIE		R+88	impossible
APPEL CONCIERGE		R+87	impossible
CHANGEMENT INTERLOCUTEUR		R+80	impossible

INDICE

Instrucciones para el instalador

Características generales	.68
Advertencias	.69
Instalación	.70
Conexiones	.71
Programación	.72
- Configuración por defecto	.72
- Entrada y salida de las operaciones de programación	.72
- Programación código de identificación desde teléfono	.72
- Programación código de identificación desde alimentador	.73
- Modalidad reconocimiento flash	.73
- Reconocimiento señal flash	.74
- Reactivación de la configuración por defecto	.74
Características técnicas	.75
Tonos y señales de llamada	.76
- Tonos de indicación	.76
- Tonos de llamada	.76

Instrucciones para el usuario

Glosario	.77
Funciones	.78
- Llamada en línea urbana	.78
- Respuesta a las llamadas entrantes	.78
- Respuesta a las llamadas desde placa exterior y apertura de la puerta	.78
- Autoactivación de la placa exterior	.79
- Cambio interlocutor	.79
- Llamada conserje	.79
- Mando de control auxiliar/ luz escalera desde el teléfono	.80
- Inhabilitación aviso acústico de llamada en entrada	.80
- Acceso a los servicios DTMF	.80
- Funciones que se pueden obtener al utilizar el teléfono bpt y con los teléfonos estándar	.81

CARACTERISTICAS GENERALES

El interfaz telefónico permite la conexión de un aparato telefónico a la línea de videoportero o portero electrónico de la serie 300.

Permite la utilización del teléfono **bpt** y de aparatos de teléfonos normales decádicos o DTMF, inalámbricos, contestador automático, módem, etc. Para instalaciones de videoportero los aparatos telefónicos no **bpt** deben conectarse utilizando un filtro separador.

El aparato también permite enviar llamadas a una centralita de conserjería y controlar los mandos abrepuerta, luz escalera centralizada, etc.

El aparato está realizado en formato DIN de 8 módulos.

Funciones básicas

- Acceso directo a la línea urbana.
- Conexión al sistema de videoportero serie 300 con función de autoactivación.
- Conexión al sistema de portero electrónico con secreto de conversación.
- Comunicación telefónica aunque la red no suministre alimentación.
- Tono de llamada diferente desde la placa exterior, centralita de conserjería y línea telefónica.
- Llamada en espera (urbana/de portero electrónico).
- Protección línea telefónica frente a sobrecargas.
- Programación del aparato desde el teléfono.
- Alimentación por red eléctrica.

ADVERTENCIAS

Leer atentamente las advertencias incluidas en este manual ya que proporcionan indicaciones importantes con respecto a la seguridad de utilización, instalación y mantenimiento.

Después de haber desembalado el aparato, comprobar que está en perfectas condiciones.

Los elementos del embalaje (bolsas de plástico, espuma de poliestireno, etc.) no se deben dejar al alcance de los niños ya que representan potenciales fuentes de peligro.

La eliminación de los embalajes se debe realizar de acuerdo con las normas vigentes.

La ejecución de la instalación tiene que respetar las normas de seguridad en vigor.

No instalar los cables telefónicos por el mismo recorrido que los cables eléctricos.

Instalar la centralita en ambientes sin polvo, lejos de equipos que puedan generar perturbaciones eléctricas de alta frecuencia como: soldadores, motores eléctricos, hornos microondas, acondicionadores de aire, etc.

Se aconseja instalar a la entrada del alimentador un interruptor de características y protección adecuado.

Antes de conectar el aparato, habrá que comprobar que los datos de la placa corresponden a los de la red de distribución.

Este aparato se tiene que utilizar únicamente para el objetivo para el que ha sido diseñado; cualquier otro tipo de uso se considerará impropio y peligroso.

El fabricante no puede ser considerado responsable por posibles daños derivados de usos impropios, erróneos o irracionales. Antes de realizar cualquier operación de limpieza o de mantenimiento, abrir el interruptor de la instalación para desconectar el aparato de la red de alimentación eléctrica.

En caso de avería y/o mal funcionamiento del aparato, habrá que desconectarlo de la alimentación eléctrica y no manipularlo.

Si es necesario realizar alguna reparación, habrá que dirigirse únicamente a un centro de asistencia técnica autorizado por el fabricante.

Si no se respetan estas advertencias, se compromete gravemente la seguridad del aparato.

El instalador tendrá que asegurarse de que la información dirigida al usuario, donde esté prevista, se entregue junto a los aparatos.

Todos los aparatos que forman la instalación se tienen que utilizar únicamente para el objetivo para el que han sido diseñados.

INSTALACION

El interfaz se presenta en un módulo bajo de 8 unidades y se puede instalar sin protege bornes en cajas dotadas de guía DIN (EN 50022).

Por lo que respecta a las dimensiones véase la fig. 1A.

También se puede instalar en la pared, con protege bornes, utilizando la guía DIN que se entrega junto al aparato.

Por lo que respecta a las dimensiones véase la fig. 1B.

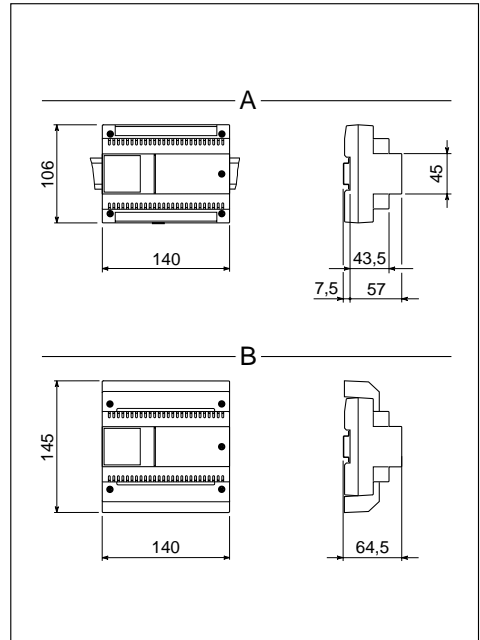

Fig. 1

CONEXIONES

Para acceder a las borneras extraer las tapas protectoras. Se aconseja utilizar cable telefónico de 6/10 para realizar la conexión de los teléfonos.

Distancia máxima entre interfaz telefónico y teléfono: 100 m.

NOTA. El aparato debe conectarse sólo con líneas telefónicas analógicas, no con líneas digitales ISDN.

Función de los bornes

Bornera T (línea telefónica)

ae línea telefónica entrante

be línea telefónica entrante

au línea telefónica saliente

bu línea telefónica saliente

Bornera IN

B entrada línea videoportero

Bornera A

~ } red
~ }

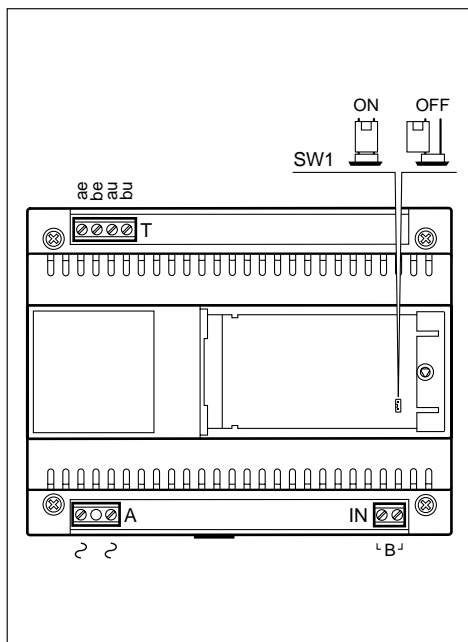

Fig. 2

NOTA. Cuando está aplicado (ON) el puente **SW1** el aparato inhabilita la programación desde el teléfono.

PROGRAMACION

Configuración por defecto

- Modalidad reconocimiento flash: homologado.
- Código programado para conexiones en equipos sistema 300: 65535.
- Interceptación flash: deshabilitada.

Entrada y salida de las operaciones de programación

Para entrar en modo programación desde el teléfono conectado a el interfaz telefónico:



Descolgar el auricular

o



pulsar la tecla manos libres.



Pulsar la tecla de conmutación portero electrónico/ teléfono multifunción.



Marcar **9999**.

Durante esta fase se puede ejecutar una o varias operaciones de programación consecutivas.

El tecleo de los códigos de programación debe ser efectuado durante la pausa del tono de programación.

Para salir de la fase de programación:



Descolgar el auricular

o



pulsar la tecla manos libres.

Después de esta operación se tendrá que oír un tono doble como invitación a realizar la programación.



Marcar **9999**.

Al final se oirá el tono de línea urbana.

Programación del código de identificación desde el teléfono



Descolgar el auricular

o



pulsar la tecla manos libres.

Después de esta operación se tendrá que oír un tono doble como invitación a realizar la programación.



Marcar **60**.



Teclear el código de usuario (de 00000 a 65535).

Al terminar se oirá un tono triple de confirmación.



Colgar el auricular

o



pulsar la tecla manos libres.

PROGRAMACION

Programación del código de identificación desde el alimentador

Predisponer el alimentador XA/300LR para la programación de los derivados internos manteniendo apretado el botón SERVICE durante por lo menos 3 segundos.

Entrar en programación IT/300.

Pulsar la tecla activación automática o marcar R86.

Enviar el código apretando el botón de llamada, correspondiente al aparato que se está programando, desde la placa exterior.

Salir de la programación IT/300.

Repetir el procedimiento con todos los derivados a programar.

Para terminar la programación de todos los aparatos de la instalación apretar brevemente el botón SERVICE del alimentador XA/300LR.

Modalidad reconocimiento flash



Descolgar el auricular

o



pulsar la tecla manos libres.

Después de esta operación se tendrá que oír un tono doble como invitación a realizar la programación.



Marcar 20.



Marcar 0 para el reconocimiento flash estándar homologado

o



1 para el reconocimiento flash prolongado.

Al terminar se oirá un tono triple de confirmación.



Colgar el auricular

o



pulsar la tecla manos libres.

PROGRAMACION

Reconocimiento señal flash



Descolgar el auricular

o



pulsar la tecla manos libres.

Después de esta operación se tendrá que oír un tono doble como invitación a realizar la programación.



Marcar **63**.



Marcar **0** para deshabilitar el reconocimiento de la señal flash (conexión al teléfono **bpt**)

o



1 para habilitar el reconocimiento de la señal flash (conexión al teléfono DTMF genérico).

Al terminar se oirá un tono triple de confirmación.



Colgar el auricular

o



pulsar la tecla manos libres.

Reactivación de la configuración por defecto



Descolgar el auricular

o



pulsar la tecla manos libres.

Después de esta operación se tendrá que oír un tono doble como invitación a realizar la programación.



Marcar **00**.

Al terminar se oirá un tono triple de confirmación.



Colgar el auricular

o



pulsar la tecla manos libres.

CARACTERISTICAS TECNICAS

- Alimentación: 230Vca - 50 Hz.
- Consumo: 6VA máx.
- Tensión de salida: 24V.
- Tensión de llamada: 50V ef./50 Hz.
- Longitud máx. de los cables de conexión entre alimentador, interfaz y derivado: 250 m (cable telefónico de 6/10).
- Cantidad derivados en la misma línea: 5 máx. (si hay derivados vídeo utilizar un distribuidor).
- Protección electrónica reactivable.
- Desviación de frecuencia: según las normas CCITT.
- Habilitación monitor durante la conversación.
- Duración tiempo flash (R) programable.
- Conexión a la línea urbana incluso cuando falta alimentación.
- Temperatura de funcionamiento: de 0 °C a +35 °C.
- Humedad relativa: 90% sin condensación.
- Clase de aislamiento II.
- Dimensiones: módulo de 8 unidades bajo para guía DIN.
- Frecuencia tonos de indicación: 375 Hz.

El aparato está homologado según las normas CTR 21 y cumple con la norma EN 60950, relativa a la seguridad eléctrica y con la directiva 89/336/EEC modificada por la 93/68/EEC, relativas a la compatibilidad electromagnética.

Aprobación europea expedida por
BZT-ETS CERTIFICATION GmbH

CE 0681 X

TONOS Y SEÑALES DE LLAMADA

Tonos de indicación

FUNCION	TIEMPO (segundos)							
	0	1	2	3	4	5	6	7
Programación	■ ■		■ ■		■ ■		■ ■	
Confirmación de final de programación	■ ■ ■		■ ■ ■		■ ■ ■		■ ■ ■	
Espera	■ ■				■ ■			
Aviso	■					■		

■ = Nota _ = Pausa

Tonos de llamada

FUNCION	TIEMPO (segundos)							
	0	1	2	3	4	5	6	7
Urbana	■ ■ ■ ■					■ ■ ■ ■		
Placa exterior	■ ■ ■ ■	■ ■				■ ■ ■ ■	■ ■	
Centralita de conserjería	■ ■ ■ ■	■ ■	■ ■			■ ■ ■ ■	■ ■	■ ■

■ = Nota _ = Pausa

GLOSARIO

Teléfono

Permite la comunicación con la placa exterior y además puede controlar la apertura de la puerta.

Por defecto

Con estas palabras se define la programación establecida por el fabricante.

Flash (R)

Si se pulsa esta tecla en el teléfono multifunción conectado, se prepara el interfaz para recibir un mando de control (no un número telefónico) del teclado.

Línea urbana

Conexión que permite la comunicación con los usuarios de la red telefónica conmutada.

Placa exterior

Permite que el visitante pueda efectuar una llamada al usuario y pueda conversar. Si dispone de cámara transmitirá la imagen al videoportero de casa.

Teléfono multifunción

Aparato que normalmente permite realizar y recibir llamadas de la línea telefónica; con la centralita IT/200 el teléfono multifunción también se puede utilizar como portero electrónico.

Teléfono multifunción decádico

Teléfono multifunción de disco con dial de diez números; algunos teléfonos con teclado también son decádicos: el teléfono es decádico si, cuando se marca un número, se oyen los impulsos de los pasos.

Teléfono multifunción multifrecuencia

También se llama MF o DTMF, es el teléfono multifunción más moderno. Un teléfono multifunción es multifrecuencia si, cuando se marca un número, en el auricular se oyen los tonos.

Videoportero

Además de las funciones del portero electrónico normal, dispone de una pantalla donde aparece el visitante que se encuentra en la placa exterior.

FUNCIONES

Llamada en línea urbana

Se puede realizar una llamada de la manera habitual, como con cualquier otro aparato telefónico.



Descolgar el auricular

o



pulsar la tecla manos libres.



Marcar en el teclado el número deseado.



Una vez haya finalizado la conversación, colgar el auricular

o



pulsar la tecla manos libres.

Respuesta a las llamadas entrantes



Descolgar el auricular

o



pulsar la tecla manos libres.



Una vez haya finalizado la conversación, colgar el auricular

o



pulsar la tecla manos libres.

El teléfono multifunción suena con un tono diferente dependiendo si la llamada procede de una línea urbana o de la placa exterior.

Véase el capítulo TONOS Y SEÑALES DE LLAMADA.

Respuesta a las llamadas desde la placa exterior y apertura de la puerta



Descolgar el auricular

o



pulsar la tecla manos libres.



Si se desea hacer entrar a quien ha llamado, pulsar la tecla abrepuerta (en teléfonos multifunción **bpt**, si se utilizan otros teléfonos multifunción habrá que consultar la tabla correspondiente).



Colgar el auricular

o



pulsar la tecla manos libres.

NOTA. Si el interfaz se ha programado con la función RECONOCIMIENTO SEÑAL FLASH deshabilitada, no se podrá ejecutar el mando de control cuando se esté en comunicación con la línea urbana si se trata de un teléfono multifunción estándar multifrecuencia.

FUNCIONES

Autoactivación de la placa exterior

Se puede activar la placa exterior para satisfacer cualquiera de las siguientes exigencias (con la instalación libre):

- vigilar el exterior con audio y vídeo (si la placa exterior dispone de cámara);
- intercambiar las placas exteriores;
- activar el abrepuerta.
- activar los mandos auxiliares.

Cambio interlocutor

Este servicio permite que el usuario, en comunicación con una línea exterior o con la placa exterior, puede responder a una llamada procedente de la otra línea y poner a la espera la comunicación en curso.

El interlocutor que permanece a la espera lo sabe gracias a que oye un tono acústico.

NOTA. Durante la conversación, se informa al usuario que tiene otra llamada entrante mediante un aviso acústico.

Para cambiar de interlocutor durante una conversación:



Pulsar la tecla de conmutación portero electrónico/teléfono (en teléfonos **bpt**, si se utilizan otros teléfonos habrá que consultar la tabla correspondiente).

NOTA. Si el interfaz se ha programado con la función RECONOCIMIENTO SEÑAL FLASH deshabilitada, no se podrá ejecutar el mando de control cuando se esté en comunicación con la línea urbana si se trata de un teléfono multifunción estándar multifrecuencia.

Llamada conserje



Descolgar el auricular

o



pulsar la tecla manos libres.

Esperar el tono de invitación a la selección.



Pulsar la tecla de llamada conserje (en teléfonos **bpt**, si se utilizan otros teléfonos habrá que consultar la tabla correspondiente).



Una vez haya finalizado la conversación, colgar el auricular

o



pulsar la tecla manos libres.

NOTA. Si el interfaz se ha programado con la función RECONOCIMIENTO SEÑAL FLASH deshabilitada, no se podrá ejecutar el mando de control cuando se esté en comunicación con la línea urbana si se trata de un teléfono multifunción estándar multifrecuencia.

FUNCIONES

Mando de control auxiliar/luz escalera desde el teléfono multifunción



Descolgar el auricular

o



pulsar la tecla manos libres.

Esperar el tono de invitación a la selección.



Pulsar la tecla auxiliar (en teléfonos **bpt**, si se utilizan otros teléfonos habrá que consultar la tabla correspondiente).



Colgar el auricular

o



pulsar la tecla manos libres.

NOTA. Si el interfaz se ha programado con la función RECONOCIMIENTO SEÑAL FLASH deshabilitada, no se podrá ejecutar el mando de control cuando se esté en comunicación con la línea urbana si se trata de un teléfono multifunción estándar multifrecuencia.

Inhabilitación aviso acústico de llamada en entrada



Marcar **R83** antes de marcar el número de teléfono.

Durante todo el tiempo de la conversación el tono de aviso queda inhabilitado.

Utilizar esta función cuando se realiza la conexión con un módem.





Si se desea obtener automáticamente la inhabilitación es preciso añadir la serie de caracteres **!83**, (ver las instrucciones del software de la conexión telefónica).

Acceso a los servicios DTMF

El acceso es posible si el interfaz se ha programado con la función RECONOCIMIENTO SEÑAL FLASH deshabilitada. También es posible si se está en comunicación con la línea urbana y sin llamadas desde la placa exterior, siempre y cuando, el interfaz se haya programado con la función RECONOCIMIENTO SEÑAL FLASH habilitada.

FUNCIONES

Funciones que se pueden obtener al utilizar el teléfono multifunción **bpt** y con los teléfonos estándar

	TELEFONO BPT	TELEFONO MULTIFRECUENCIA	TELEFONO DECADICO
PROGRAMACION	sí	sí	no posible
LLAMADA URBANA	directo	directo	directo
RECEPCION LLAMADAS URBANAS/TELEFONICAS	sí	sí	sí
ACCESO A LOS SERVICIOS DTMF	sí	sí	no posible
AUTOACTIVACION	 (monitor)	R+86	no posible
ABREPUERTA		R+85	no posible
AUXILIAR/LUZ ESCALERA		R+88	no posible
LLAMADA CONSERJE		R+87	no posible
CAMBIO INTERLOCUTOR		R+80	no posible

INDICE

Instruções para o instalador

Generalidade	.84
Advertências	.85
Instalação	.86
Ligações	.87
Programação	.88
- Configuração de default	.88
- Entrada e saída das operações de programação	.88
- Programação do código de identificação de telefone	.88
- Programação do código de identificação do alimentador	.89
- Modalidade reconhecimento flash	.89
- Interceptação flash	.90
- Restabelecimento da configuração de default	.90
Características técnicas	.91
Tons e ritmos	.92
- Tons de sinalização	.92
- Ritmos de chamada	.92

Instruções para o utente

Glossário	.93
Funções	.94
- Chamada sobre linha urbana	.94
- Resposta às chamadas que chegam	.94
- Resposta à chamada da placa botoneira e abertura da porta	.94
- Auto-inserção na placa botoneira	.95
- Troca interlocutor	.95
- Chamada porteiro	.95
- Comando auxiliar/luz escadas do telefone	.96
- Desabilitação do aviso acústico quando chega a chamada	.96
- Acesso aos serviços Telecom DTMF	.96
- Funções que se podem obter com a utilização do telefone bpt e com telefones standard	.97

GENERALIDADE

A interface telefónica permite a ligação de um aparelho telefónico à linha videoproteiro e telefone de porteiro série 300.

Permite a utilização, para além do telefone **bpt**, de normais aparelhos telefónicos “decádicos” ou DTMF, cordless, secretária automática, modem, etc. Para instalações de videoproteiro, os aparelhos telefónicos que não sejam **bpt** devem ser ligados através de um filtro separador.

O aparelho consente enviar mesmo chamadas a uma central de portaria e de comandar a abertura da porta, luz das escadas centralizada, etc.

O aparelho é realizado num contentor DIN com 8 módulos.

Funções base

- Acesso directo à linha urbana.
- Ligação ao sistema videoproteiro série 300 com função de auto inserção.
- Ligação ao sistema telefone de porteiro com segredo de conversação.
- Comunicação telefónica mesmo em ausência de alimentação da rede.
- Chamada diversificada da placa botoneira, central de portaria e linha telefónica.
- Colocação da comunicação em estado de espera (urbana/telefónica).
- Protecção linha telefónica.
- Programação do aparelho através do telefone.
- Alimentação da rede eléctrica.

ADVERTÊNCIAS

Ler com atenção as advertências contidas no seguinte manual porque fornecem importantes indicações que dizem respeito à segurança do uso, da instalação e manutenção.

Depois de ter tirado a embalagem certificar-se da integridade do aparelho.

Os elementos da embalagem (sacos de plástica, poliestireno expando, etc.) não devem ser deixados ao alcance das crianças porque constituem potenciais fontes de perigo.

A eliminação das embalagens deve ser efectuada no respeito das normas vigentes. A execução da instalação deve corresponder às normas de segurança vigentes.

Não passar os cabos telefónicos em percursos comuns aqueles dos cabos eléctricos.

Instalar a central em ambientes não poeiros, longe de aparelhagens que possam gerar distúrbios eléctricos de alta frequência, tais como soldadoras, motores eléctricos, fornos a micro-ondas, condicionadores de ar, etc.

E' oportuno prever a montante do alimentador um interruptor apropriado de seccionamento e protecção.

Antes de ligar o aparelho certificar-se que os dados de chapa sejam correspondentes aqueles da rede de distribuição.

Este aparelho deverá ser destinado unicamente ao uso para o qual foi expressamente concebido; qualquer uso diverso é considerado impróprio e perigoso.

O fabricante não pode ser considerado responsável por eventuais danos que derivam de usos impróprios, erróneos e irracionais.

Antes de efectuar qualquer operação de limpeza ou de manutenção, desligar o aparelho da rede de alimentação eléctrica, abrindo o interruptor da instalação.

No caso de avarias e/ou mau funcionamento do aparelho desligá-lo da alimentação e não o tocar.

Para a eventual reparação dirigir-se somente a um centro de assistência técnica autorizado pelo fabricante.

O não respeito de quanto acima pode comprometer a segurança do aparelho.

O instalador deve certificar-se que as informações para o utente, onde previsto, estejam presentes sobre os aparelhos.

Todos os aparelhos que fazem parte do equipamento devem ser destinados exclusivamente para o uso para o qual foram concebidos.

INSTALAÇÃO

O aparelho, realizado num contentor de 8 unidades baixo, pode ser instalado sem cobertura dos bornes em caixas dotadas de guia DIN (EN 50022).

Para as dimensões totais ver a fig. 1A.

Ou então pode ser instalado a parede, com cobertura dos bornes, utilizando a guia DIN em dotação.

Para as dimensões totais ver a fig. 1B.

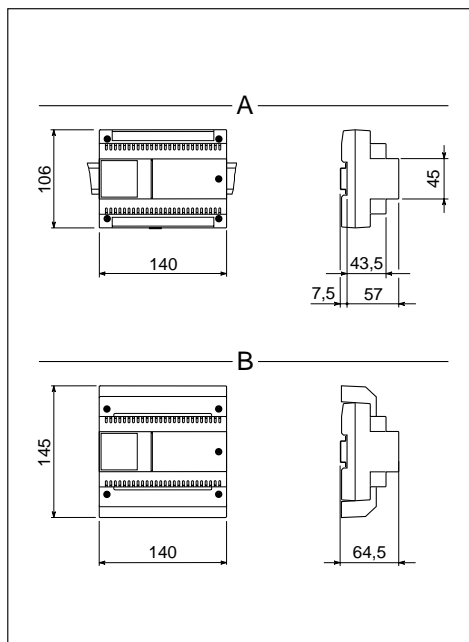

Fig. 1

LIGAÇÕES

Para ter acesso a la placa de bornes tirar a cobertura dos bornes. Se aconselha de utilizar para a ligação dos telefones, cabo telefónico de 6/10.

Distância máxima entre a interface telefónica e telefone: 100 m.

NOTA. O aparelho só deve ser ligado a linhas telefónicas analógicas, não a linhas digitais ISDN.

Função dos bornes

Placa de bornes T (linha telefónica)

ae linha telefónica que entra

be linha telefónica que entra

au linha telefónica que sai

bu linha telefónica que sai

Placa de bornes IN

B entrada da linha do videoporteiro

Placa de bornes A

~ } rede
~ }

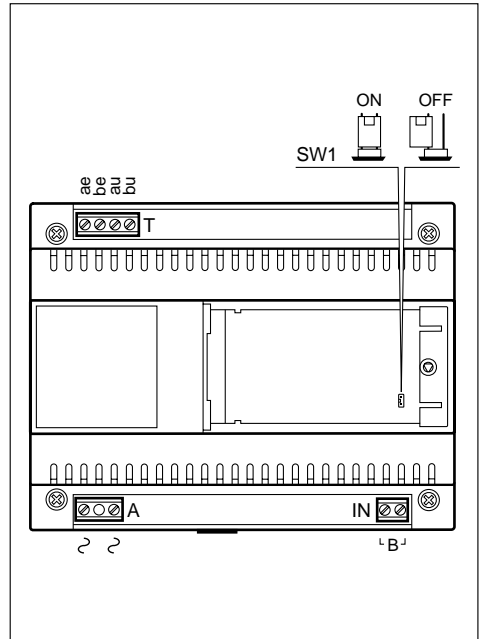

Fig. 2

NOTA. Quando está inserido (ON) da ligação em ponte SW1 o aparelho corta a habilitação da programação do telefone.

PROGRAMAÇÃO

Configuração de default

- Modalidade reconhecimento flash: homologado.
- Código programado para a ligação em instalações sistema 300: 65535.
- Interceptação flash: desabilitada.

Entrada e saída das operações de programação

Para entrar em programação pelo telefone ligado à interface telefónica:



Levantar o auscultador
ou então



premir a tecla viva-voz.



Premir a tecla de comutação
telefone porteiro/telefone.



Digitar **9999**.

Durante esta fase podem-se efectuar uma ou diversas programações consecutivas.

A inserção dos códigos de programação deve ser executada durante a pausa do tom de programação.

Para sair da fase de programação:



Levantar o auscultador
ou então



premir a tecla viva-voz.

Depois desta operação se deve ouvir um tom duplo de convite à programação.



Digitar **9999**.

Ao fim se ouvirá o tom da linha urbana.

Programação do código de identificação do telefone



Levantar o auscultador
ou então



premir a tecla viva-voz.

Depois desta operação se deve ouvir um tom duplo de convite à programação.



Digitar **60**.



Digitar o código utente
(desde 00000 até 65535).

Ao fim se deve ouvir um triplo tom de confirmação.



Tornar a colocar o auscultador no suporte
ou então



premir a tecla viva-voz.

PROGRAMAÇÃO

Programação do código de identificação do alimentador

Predispor o alimentador XA/300LR em programação derivados internos, pressionando o botão SERVICE pelo menos por 3 segundos.

Entrar em programação IT/300.

Premir a tecla auto-inserção ou digitar R86.

Enviar o código pressionando o botão de chamada, relativo ao aparelho em programação, da placa botoneira.

Sair da programação IT/300.

Repetir o procedimento para todos os derivados que se querem programar.

Para terminar a programação de todos os aparelhos do equipamento, pressionar brevemente o botão SERVICE do alimentador XA/300LR.

Modalidade reconhecimento flash



Levantar o auscultador
ou então



premir a tecla viva-voz.

Depois desta operação se deve ouvir um tom duplo de convite à programação.



Digitar 20.



Digitar 0 para reconhecimento flash homologado
ou então



1 para reconhecimento flash longo.

Ao fim se deve ouvir um triplo tom de confirmação.



Tornar a colocar o auscultador no suporte
ou então



premir a tecla viva-voz.

PROGRAMAÇÃO

Interceptação flash



Levantar o auscultador
ou então



premir a tecla viva-voz.

Depois desta operação se deve ouvir um tom duplo de convite à programação.



Digitar **63**.



Digitar **0** para interceptação flash desabilitado (ligação ao telefone **bpt**)
ou então



1 para interceptação flash habilitada (ligação ao telefone DTMF genérico).

Ao fim se deve ouvir um triplo tom de confirmação.



Tornar a colocar o auscultador no suporte
ou então



premir a tecla viva-voz.

Restabelecimento da configuração de default



Levantar o auscultador
ou então



premir a tecla viva-voz.

Depois desta operação se deve ouvir um tom duplo de convite à programação.



Digitar **00**.

Ao fim se deve ouvir um triplo tom de confirmação.



Tornar a colocar o auscultador no suporte
ou então



premir a tecla viva-voz.

CARACTERISTICAS TECNICAS

- Alimentação: 230Vca - 50 Hz.
- Absorção: 6VA máx.
- Tensão de saída: 24V.
- Tensão de chamada 50V ef./50 Hz.
- Comprimento máx. dos cabos de conexão entre alimentador, interface e derivado: 250 m (cabo telefónico de 6/10).
- Quantidade de derivados sobre a mesma linha: 5 máx. (se existirem derivados vídeo, utilizar um distribuidor).
- Protecção electrónica que se pode restabelecer.
- Deflexão de frequência: conforme as normas CCITT.
- Habilitação monitor pela duração da conversação.
- Duração tempo de flash (R) programável.
- Ligação linha urbana mesmo em ausência de alimentação.
- Temperatura de funcionamento: desde 0 °C até +35 °C.
- Humidade relativa: 90% sem condensação.
- Classe de isolamento II.
- Dimensões: módulo de 8 unidades baixo por guia DIN.
- Frequência tons de sinalização: 375 Hz.

O aparelho foi homologado segundo as normas CTR 21 e satisfaz a norma EN 60950, relativa à segurança eléctrica, e a directiva 89/336/EEC modificada com 93/68/EEC, relativas à compatibilidade electromagnética.

Aprovação europeia passada pelo BZT-ETS CERTIFICATION GmbH

CE 0681 X

TONS E RITMOS

Tons de sinalização

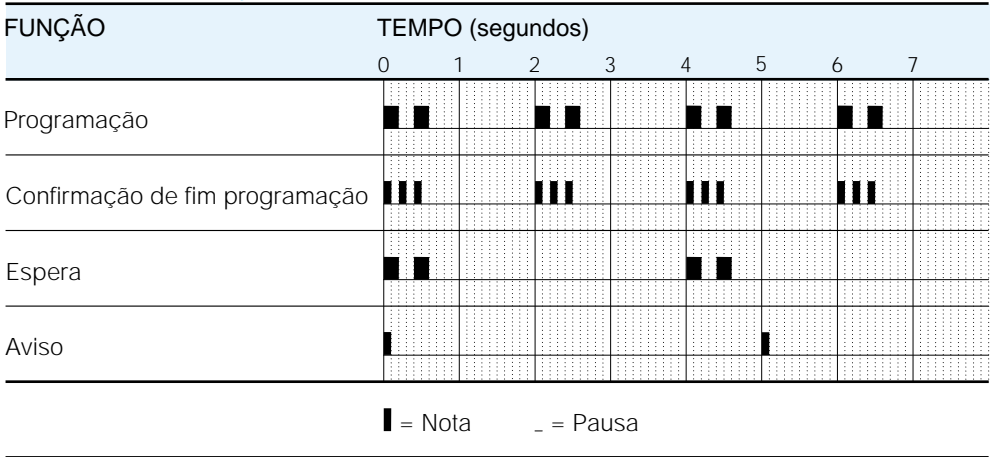

Ritmos de chamada

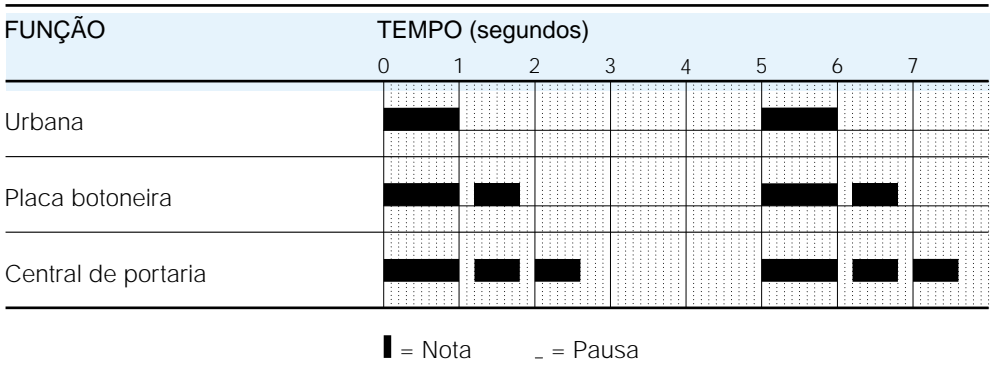

GLOSSARIO

Telefone porteiro

Permite de comunicar com a placa botoneira e de comandar a abertura da porta.

Default

Com este termo são definidas todas as predisposições ou programação efectuada pelo fabricante.

Flash (R)

Premindo esta tecla do telefone ligado se predispõe a interface a receber um comando (e não um número telefónico) do teclado.

Linha urbana

Ligação que permite de comunicar com os utentes da lista telefónica.

Placa botoneira

Permite ao visitante de efectuar a chamada ao utente e de conversar.
Se for dotado de telecâmara, transmite as imagens ao videotelefone em casa.

Telefone

Aparelho que normalmente permite efectuar e receber telefonemas na linha urbana; com a central IT/200 o telefone pode ser utilizado mesmo como telefone porteiro.

Telefone “decádico”

Telefone com disco de números; mesmo alguns telefones com teclado são “decádico”: o telefone é “decádico” se, formando um número, ao auscultador se ouvem os impulsos.

Telefone multi-frequência

Também chamado MF ou DTMF, é o telefone mais moderno.
Um telefone é multi-frequência se, formando um número, ao auscultador se ouvem tons.

Videoporteiro

Para lá das normais funções de telefone porteiro, permite ver no ecrã o visitante que chama da placa botoneira.

FUNÇÕES

Chamada sobre linha urbana

É possível dirigir as chamadas no modo habitual, como em cada um dos outros aparelhos.



Levantar o auscultador
ou então



premir a tecla viva-voz.



Formar no teclado o número desejado.



Tornar a colocar o auscultador no suporte
ou então



premir a tecla viva-voz.

Resposta às chamadas que chegam



Levantar o auscultador
ou então



premir a tecla viva-voz.



Ao fim da conversação tornar a colocar o auscultador no suporte
ou então



premir a tecla viva-voz.

O telefone toca com ritmos diferentes em base à proveniência da chamada, se de uma linha urbana ou da placa botoneira. Ver capítulo TONS E RITMOS de toque.

Resposta à chamada da placa botoneira e abertura da porta



Levantar o auscultador
ou então



premir a tecla viva-voz.



Se se desejasse fazer entrar a pessoa que chama, premir a tecla de abertura da porta (para telefones **bpt**, para outros telefones consultar a tabela recapitulativa).



Tornar a colocar o auscultador no suporte
ou então



premir a tecla viva-voz.

NOTA. Se a interface é programada com a função INTERCEPTAÇÃO FLASH desabilitada, não é possível de um telefone standard multi-frequência, efectuar o comando quando se está em comunicação com a linha urbana.

FUNÇÕES

Auto-inserção na placa botoneira

É possível activar a placa botoneira para qualquer uma das seguintes exigências (com o equipamento livre):

- vigilar o externo com audio e vídeo (se a placa botoneira for dotada de telecâmara);
- permutar as placas botoneiras;
- activar a abertura da porta.
- activar os comandos auxiliares.

Troca interlocutor

Este serviço permite ao utente, em comunicação com uma linha externa ou placa botoneira, de responder a uma chamada proveniente da outra linha mantendo em estado de espera a comunicação em curso.

O interlocutor não em conversação é informado desta condição através de um tom acústico.

NOTA. Durante a conversação o utente é informado da chamada que está a chegar com um aviso acústico.

Para mudar interlocutor durante uma conversação:



Premir a tecla de comutação telefone porteiro/telefone (para telefones **bpt**, para outros telefones consultar a tabela recapitulativa).

NOTA. Se a interface é programada com a função INTERCEPTAÇÃO FLASH desabilitada, não é possível de um telefone standard multi-frequência, efectuar o comando quando se está em comunicação com a linha urbana.

Chamada porteiro



Levantar o auscultador ou então



premir a tecla viva-voz.

Esperar o tom de convite à selecção.



Premir a tecla de chamada porteiro (para telefones **bpt**, para outros telefones consultar a tabela recapitulativa).



Ao fim da conversação tornar a colocar o auscultador no suporte

ou então



premir a tecla viva-voz.

NOTA. Se a interface é programada com a função INTERCEPTAÇÃO FLASH desabilitada, não é possível de um telefone standard multi-frequência, efectuar o comando quando se está em comunicação com a linha urbana.

FUNÇÕES

Comando auxiliar/luz escadas do telefone



Levantar o auscultador
ou então



premir a tecla viva-voz.

Esperar o tom de convite à selecção.



Premir a tecla de chamada auxiliar (para telefones **bpt**, para outros telefones consultar a tabela recapitulativa).



Tornar a colocar o auscultador no suporte
ou então



premir a tecla viva-voz.

NOTA. Se a interface é programada com a função INTERCEPTAÇÃO FLASH desabilitada, não é possível de um telefone DTMF, efectuar o comando quando se está em comunicação com a linha urbana.

Desabilitação do aviso acústico quando chega a chamada



Digitar **R83** antes de formar o número telefónico.

Durante todo o tempo da conversação o tom de aviso fica desabilitado.

Utilizar esta função quando for efectuada a ligação com um modem.





Se se deseja obter a desabilitação em automático, acrescentar a série de caracteres **!83**, (ver as instruções do software da conexão telefónica).

Acesso aos serviços Telecom DTMF

O acesso é possível sempre que se configurou a interface como INTERCEPTAÇÃO FLASH desabilitada, enquanto é possível só em comunicação com a linha urbana e na ausência de chamadas da placa botoneira telefone porteiro, quando é configurada como INTERCEPTAÇÃO FLASH habilitada.

FUNÇÕES

Funções que se podem obter com a utilização do telefone **bpt** e com telefones standard

	TELEFONE BPT	TELEFONE MULTI-FREQUENCIA	TELEFONO DECADICO
PROGRAMAÇÃO	sim	sim	não possível
CHAMADA URBANA	directo	directo	directo
RECEPÇÃO CHAMADAS URBANAS/TELEFONICAS	sim	sim	sim
ACESSO AOS SERVIÇOS TELECOM EM DTMF	sim	sim	não possível
AUTO-INSERÇÃO	 (monitor)	R+86	não possível
ABERTURA PORTA		R+85	não possível
AUXILIAR/LUZ ESCADAS		R+88	não possível
CHAMADA PORTEIRO		R+87	não possível
MUDANÇA INTERLOCUTOR		R+80	não possível

